



CABINET Fume Extraction Solutions

FC 1000 iQ T (Tall) FumeCAB

The complete **cabinet fume extraction** solution for a broad range of applications, with a taller, larger working area.

Partial enclosures are becoming the recommended extraction option for a variety of applications. Government bodies, including the HSE in the UK are now making direct reference through guidance documentation such as the new HSG258 to their use.

The FumeCAB 1000 iQ T integrated filtration system has been designed to ensure compliance with the latest regulations. It provides users with an extra depth of working space for taller applications.

BOFA's iQ Operating System and ultra-bright slimline energy saving LED lights come as standard, making this system an ideal choice of fume extraction for a wide variety of applications.

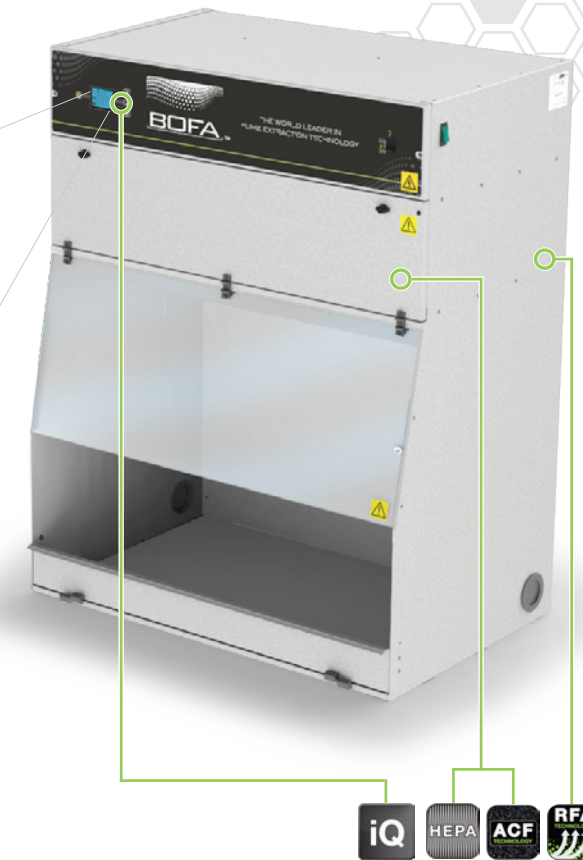
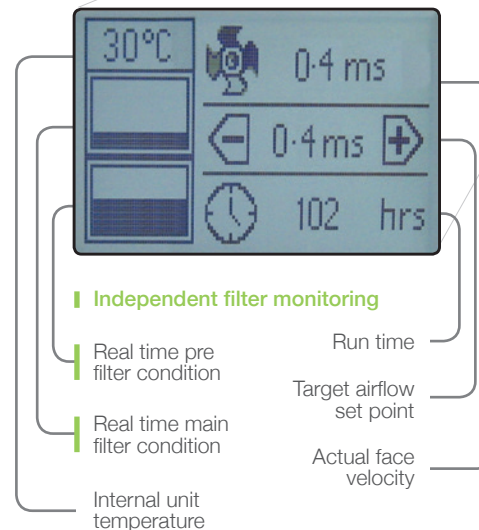

BOFA's safe and easy innovative front loading Cam filter replacement system.

STANDARD FEATURES:

- Certified to BS 7989:2001 - Recirculatory filtration fume cabinet specification
- Ensures operational compliance with HSG258 guidelines
- Reverse flow filter technology
- Automatic flow control system
- Energy saving ultra-bright slim line LED lighting
- Twin coated anti UV / anti splash protective Polycarbonate visor
- Combined HEPA/Gas filter incorporating ACF technology
- Filters with long life and low replacement cost
- Real time airflow reading
- Independent filter condition monitoring, display and warnings
- High contrast display
- 'Run safe' operation
- Remote diagnostics via USB
- Large and extra deep working area
- Side entry blind grommets for equipment access

OPTIONAL FEATURES:

- VOC gas sensor (Volatile Organic Compound)
- Interfacing
- UV Lighting
- Optional filter medias



Take a look at the iQ animation, which explains exactly why the patented BOFA iQ Operating System provides unrivalled control and data management for your fume extraction unit.



Patented Technology - Patent No: GB2 499 812



UNIT PART NUMBERS			UNIT OPTIONS		
Model	Voltage	Part No.	VOC Monitor	UV Lights	Stand
FumeCAB 1000 iQ Powder Coated	230V	E2252A	A2003	A2010	A1060054
	115V	E2251A			

REPLACEMENT FILTERS	
Pre Filter	Combined filter
A1030249	A1030250

TECHNICAL DATA		
	230V	115V
Dimensions (HxWxD)	1278 x 1000 x 660mm	50.3 x 39.4 x 26"
Opening Dimensions (HxWxD)	285 x 1000 x 650mm	11.2 x 39.4 x 25.6"
Cabinet Construction	Powder coated mild steel	Powder coated mild steel
Face Velocity	0.4m/s	78.7ft/min
Max Face Velocity	0.6m/s	118ft/min
Electrical Data	230v 50/60Hz Full load current: 6 amps	115v 50/60Hz Full load current: 10 amps
Noise Level	< 60dBA (At typical operating speed)	
Weight	143kg	315lbs
Exhaust Outlet (Optional)	125mm	
Approvals	CE	

PRE FILTER SPECIFICATIONS	
Filter Media Construction	Filter Pad
Filter Housing	Cardboard
Filter Efficiency	H11 (99% @ 0.3 microns)

COMBINED HEPA/GAS FILTER SPECIFICATIONS	
HEPA Filter Media	Glass Fibre
HEPA Media Construction	Maxi Pleat Construction with Webbing Spacers
Filter Housing	Zintec Mild Steel
Treated Activated Carbon	17kgs
Filter Efficiency	99.997% @ 0.3 microns

OPTIONAL STAND SPECIFICATIONS	
Dimensions (HxWxD)	943 x 1029 x 669mm / 37.1 x 40.5 x 26.3"
Stand Construction	Powder coated mild steel

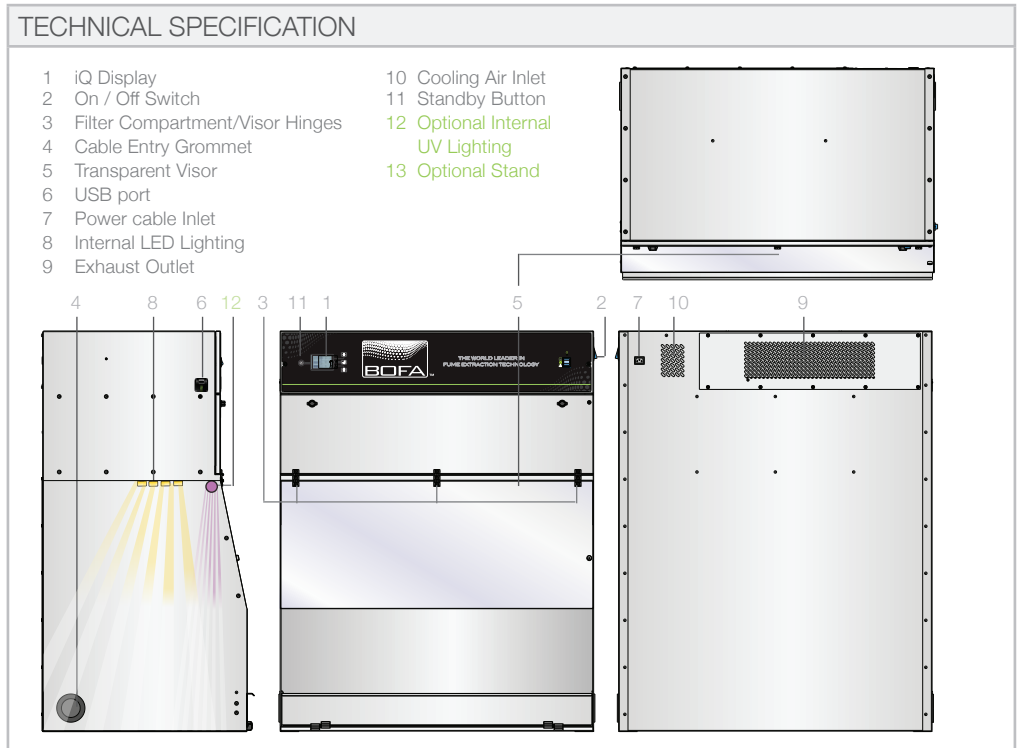
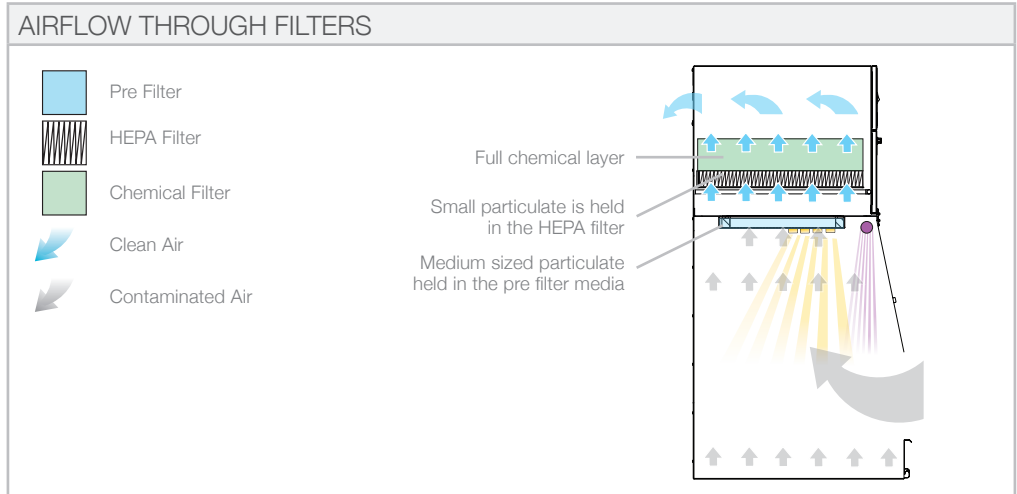
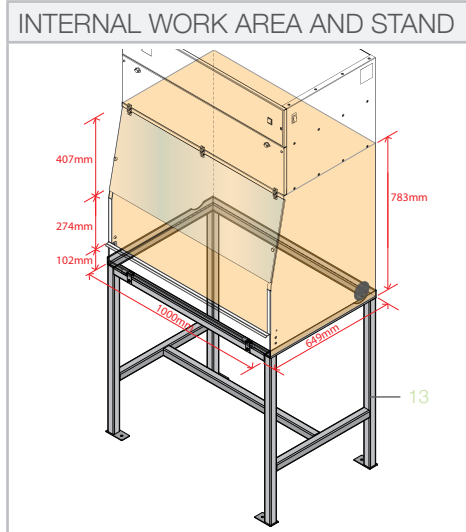

Other hose kits and filters are available. All of the above units are fitted with our standard filter combinations. For specific applications please call us for details. Replacement filters should always be ordered using the part number on the filters inside your extractor to ensure the correct filter is ordered. Datasheet correct at time of print.

FumeCAB1000iQ:16/11/16v:1.3



BOFA INTERNATIONAL LTD

Tel: +44 (0) 1202 699 444 Fax: +44 (0) 1202 699 446 Email: sales@bofa.co.uk Web: www.bofa.co.uk

BOFA AMERICAS, INC

Tel: (618) 205 5007 Fax: (866) 707 2632 Email: sales@bofaamericas.com Web: www.bofaamericas.com

