

technical furniture



TRESTON®

ergonomics



design

FUNCTIONAL FURNITURE FOR PRODUCTIVE WORK

Treston is one of the leading technical furniture suppliers in Europe, with professionals all over the world relying on our products and services. With our long experience and our continuous product development we can offer our customers solutions that help them increase the productivity of their operations.

EXPERT SOLUTIONS FOR PROFESSIONALS

We focus on two product lines: technical furniture and storage systems: with the electronics industry being one of our main customer groups. As professionals we recognize our customers' needs and know how to develop the best products to meet these needs. In addition to high quality and durability we put a lot of effort into product ergonomics and design. Due to the flexibility of our production we can offer customised solutions as well. Reliability, which is embedded in all our operations, is the cornerstone of our client centered work. It means our customers can have total confidence in the durability, functionality and high quality of our products. It also means listening to our customers, understanding their industry-specific needs, maintaining continuous co-operation and offering flexible service at every stage of the delivery chain. Having our own production facilities is one of the most significant factors contributing to the reliability of our products. By controlling the production and warehousing in our own factory we can ensure quick and reliable delivery times. Treston is an ISO 9001:2000 registered company, and our technical furniture has the GS-quality approval (TÜV).

CUSTOMISED PRODUCTS

Special products and production processes often require customised workstations. TRESTON's experience and wide range of modules can be combined to provide you with a flexible and cost effective solutions. Steel parts can also be supplied in special colours.

TRESTON NEWS

We have introduced a totally new range of chairs that has been designed in cooperation with Professor Yrjö Kukkapuro, a world famous designer. The latest addition to our product range is a high quality, LED magnifying task light, that is perfectly suited to precision work.

PACKAGING

Each TRESTON workbench and trolley comes flat packed in an individual carton with all necessary fittings and instructions. Modular elements of our products are securely packed and very easy to assemble with full instructions included.

STANDARD COLOURS

The standard colours of steel parts of our workbenches, trolleys, shelving and cabinets are shown below. Colours reproduced here are as accurate as print techniques allow.

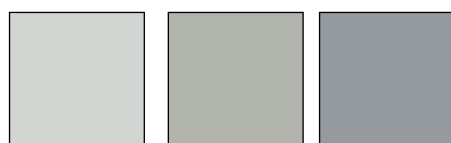

RAL 7035

RAL 7038

RAL 7045



flexibility



contents

Adjustable workbenches WB • height adjustment by allen key, retractable handle, by electric motor	4-7
Tilt workbenches WB TILT • height adjustment by allen key, retractable handle, by electric motor	5
Workbenches TP/TPH • height adjustment by allen key	8-11
Moveable benches CTR/SAP	4, 8
Heavy duty workbenches HDB/HDBL Workshop trolley RV	12-13
Steel cabinets ML	14
Drawer cabinets, dividers for drawer cabinets	15-17
Shelf cabinets HKS/HK	18
Light steel cabinets LMC	19
Power channels	19
Lighting units ZL3/OL/SL	20-21
Hooks, perforated panels	22-23
Computer accessories, bottle holder	24
Universal trolley WTR	25
Adjustable trolleys TRTA	26
Industrial trolley IT	27
Workshop trolley RV	12
Chairs X/KJ Foot rest JT	28 - 29
Industrial office screen system	30-31
Packing stations PPH	32



adjustable workbenches WB



There is a large range of workbench accessories available, see page 6-7.

Workbench WB

The WB workbench has been designed for use in demanding assembly environments. The concept is one of simplicity and good ergonomics, allowing each bench to be adapted to a variety of tasks. Electric motor, manual hand crank or allen key height adjustment cater for standing or seated users, while the generous worktop depth and broad accessory range ensure that everything is within easy reach. Another feature of this new design is the flush bench footprint; benches can be placed side-by-side, back-to-back, or right up against walls with no unnecessary gaps. You can design your workstation to fit your needs perfectly.

Worktop height can be adjusted between 700...1100 mm. The adjustment system in both cases utilises interlocking aluminium profiles, providing a strong, rigid frame.

Steel frame parts are epoxy powder coated light grey paint, RAL 7035. Worktops are of 25 mm laminated particle board, adjustable feet are provided for fine levelling.



Moveable bench CTR 705

Height adjustment with allen key between 690..990 mm. A lower shelf is integrated. Steel frame parts are epoxy powder coated light grey paint, RAL 7035. Swivel castors Ø 100 mm of which two are braked. Load capacity 75 kg/shelf static u.d.l. Dimensions 700 x 500 mm, lower shelf 700 x 415 mm.

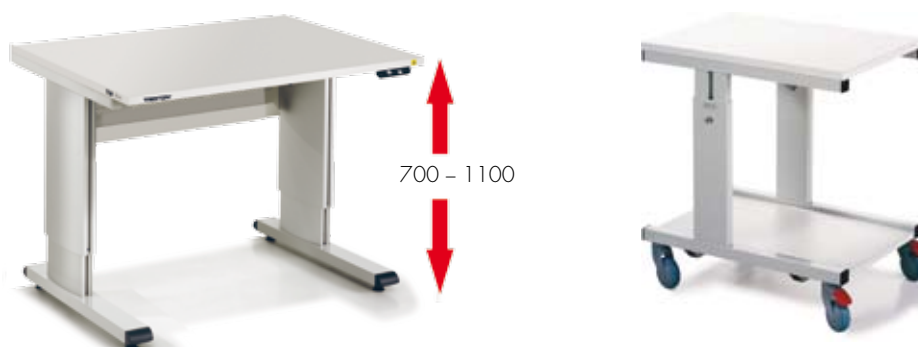

Allen-key adjustable bench WB

Code	Worktop mm	Load capacity**
WB 811	800 x 1073	250 kg
WB 815	800 x 1500	250 kg
WB 818	800 x 1800	250 kg

Handle adjustable bench WB - C

Cable tidy as standard.

Code	Worktop mm	Load capacity**
WB 811 C*	800 x 1073	200 kg
WB 815 C	800 x 1500	200 kg
WB 818 C	800 x 1800	200 kg

Electric adjustable bench WB - EL

Adjustment speed using the motor is 19 seconds min. to max. Cable tidy as standard.

Code	Worktop mm	Load capacity**
WB 811 EL*	800 x 1073	200 kg
WB 815 EL	800 x 1500	200 kg
WB 818 EL	800 x 1800	200 kg

*] To order

**] Load capacity equipment static u.d.l.

tilt adjustable workbenches WB TILT



1. Tilt workbench WB-TILT

Worktop tilt is adjusted by manual allen key, retractable handle or electric motor between 0..60°. Load capacity for this worktop is 100 kg static u.d.l. Construction as WB. Standard sizes are shown. Made to order.

2. Side worktop WB 804 ST

This new side worktop can be installed on either the right or left hand side of a WB bench to increase the surface area. Installation can be either at the same height, or lower than the main worktop with the brackets provided. Load capacity for this side worktop is 50 kg, and it is suitable for all WB models in the range. Dimensions 800 x 400 mm.

3. Corner worktop WB 1212 CT

A corner worktop can be used with two WB benches to create a 90 deg. angle setup. This unit consists of a worktop and all necessary components. It requires no additional leg frames, simply mounting to the standard benches with the brackets provided. Load capacity for this worktop is 50 kg. Dimensions 1153 x 1153 mm. Suitable for WB EL to order.

Tilt adjustment by allen key WB - TILT

Height adjustment by allen key	Height adjustment by handle	Height adjustment by electric motor	Worktop mm
WB 811 TILT*	WB 811 C TILT*	WB 811 EL TILT*	700 x 1073
WB 815 TILT*	WB 815 C TILT*	WB 815 EL TILT*	700 x 1500
WB 818 TILT*	WB 818 C TILT*	WB 818 EL TILT*	700 x 1800

Tilt adjustment by handle WB - TILT C

Height adjustment by allen key	Height adjustment by handle	Height adjustment by electric motor	Worktop mm
WB 811 TILT C*	WB 811 C TILT C*	WB 811 EL TILT C*	700 x 1073
WB 815 TILT C*	WB 815 C TILT C*	WB 815 EL TILT C*	700 x 1500
WB 818 TILT C*	WB 818 C TILT C*	WB 818 EL TILT C*	700 x 1800

Tilt adjustment by electric motor WB - TILT EL

Height adjustment by allen key	Height adjustment by handle	Height adjustment by electric motor	Worktop mm
WB 811 TILT EL*	WB 811 C TILT EL*	WB 811 EL TILT EL*	700 x 1073
WB 815 TILT EL*	WB 815 C TILT EL*	WB 815 EL TILT EL*	700 x 1500
WB 818 TILT EL*	WB 818 C TILT EL*	WB 818 EL TILT EL*	700 x 1800

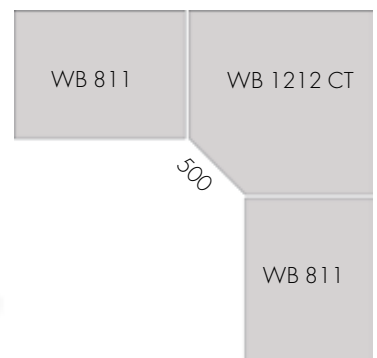

*) To order

accessories for WB workbench



The upright profiles are attached to the workbench frame through the worktop.

Accessories

Steel parts are epoxy powder coated light grey paint, RAL 7035. Shelves are of 25 mm laminated particle board.

Suitability:

- WB 811 benches can be fitted with size 100 accessories in one module
- WB 815 benches can be fitted with size 70 accessories in two modules
- WB 818 benches with one size 70 and one size 100 module.

1. Upright profiles AL2X-W

Needed for mounting accessories to benches. Includes 2 vertical and 1 horizontal profile. With 3 cable clips (CC8).

Code	Dims mm	Suitable for
AL2X 110 W	1063 x 900	WB 811
AL2X 150 W	1489 x 900	WB 815
AL2X 180 W	1789 x 900	WB 818

2. Accessory frame AKK

The accessory frame divides the space between the upright profiles into 2 modules. AKK frame includes 1 vertical and 1 horizontal profile. Useable height 500 mm.

Code	Dims mm	Suitable for
AKK 150	690 + 690	WB 815
AKK 180	690 + 990	WB 818

3. Shelf ALH

Height adjustable shelf. 25 mm laminated particle board. Load capacity 50 kg. Mount on upright profiles.

Code	Dims mm	Suitable for
ALH 110	310 x 1073	WB 811
ALH 150	310 x 1500	WB 815
ALH 180	310 x 1800	WB 818

4. Adjustable shelf ASH

Continuous adjustment for depth, height and angle. Shelf of 25 mm laminated particle board. Lipped front edge. Load capacity 35 kg static load. Mount on accessory frame.

Code	Dims mm	Suitable for
ASH 70	400 x 660	WB 815/818
ASH 100	400 x 960	WB 811/818

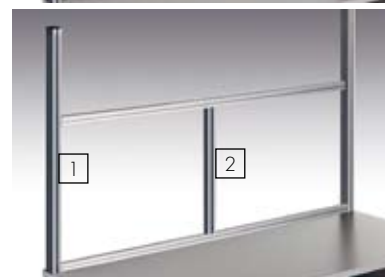
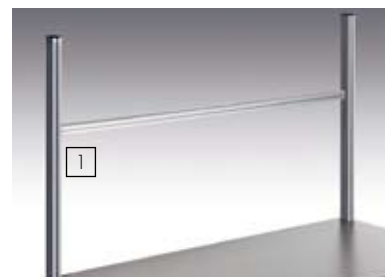

5. Bin profile BP

Aluminium profile for TRESTON stacking and picking bins. Mount on accessory frame.

Code	Dims mm	Suitable for
BP 70	length 685	WB 815/818
BP 100	length 985	WB 811/818

6. Perforated panel ARL

Perforated steel panel with 9 mm perforations at 38 mm centres. Panel hooks, page 22-23. Mount on accessory frame with screws.

Code	Dims mm	Suitable for
ARL 70	500 x 685	WB 815/818
ARL 100	500 x 985	WB 811/818

7. Support bracket HSB

Support bracket of steel for suspending power tools and lighting units. Mount on upright profiles.

Code	Length mm	Suitable for
HSB 110	1073	WB 811
HSB 150	1500	WB 815
HSB 180	1800	WB 818

8. Swivel arm with tray AKV

Lockable, angle adjustable tray with swivel radius of 360°. Length of swivel arm 590 mm. Max. load 15 kg.

Code	Tray mm	Suitable for
AKV 400	210 x 460	WB

9. Keyboard shelf WKA

Keyboard shelf with swivel arm. Epoxy powder coated steel. Load capacity 15 kg. Arm length 220 mm.

Code	Shelf mm	Suitable for
WKA	220 x 500	WB

10. Document stand WDA

Document stand A3 with swivel arm. Epoxy powder coated steel: light grey. Arm length 220 mm. Tilt 75°.

Code	Stand mm	Suitable for
WDA	440 x 300	WB

11. Cable tidy WBCT

Mount on leg frame. A cable tidy is standard equipment on motor and retractable handle bench

Code	Dims mm	Suitable for
WBCT 110*	64 x 204 x 948	WB 811
WBCT 150	64 x 204 x 1375	WB 815
WBCT 180	64 x 204 x 1675	WB 818

12. Lower shelf AT-WB

Height adjustable lower shelf, 25 mm laminated particle board. Load capacity 50 kg. Mount between aluminium profiles.

Code	Dims mm	Suitable for
AT 110 WB *	400 x 828	WB 811
AT 150 WB *	400 x 1255	WB 815
AT 180 WB *	400 x 1555	WB 818

13. Cable clip set CC

The cable clip set will hold cables etc. securely and neatly in place along the bench frame. The clips locate in the 8 mm profile slot.

Code	Set	Suitable for
CC8	5 pieces	AL2X

*) To order

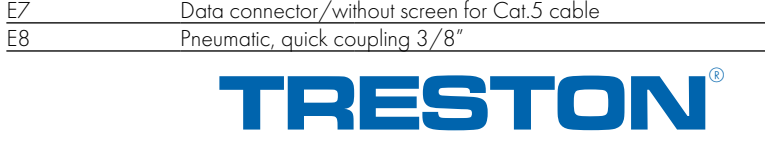
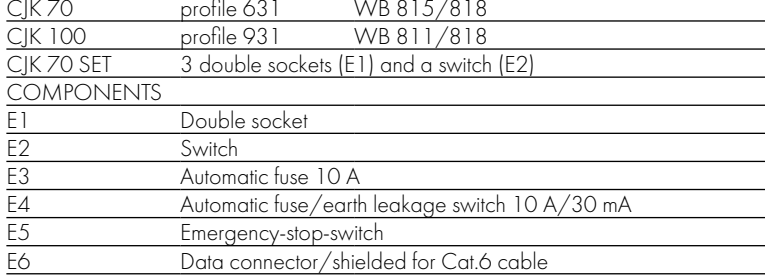
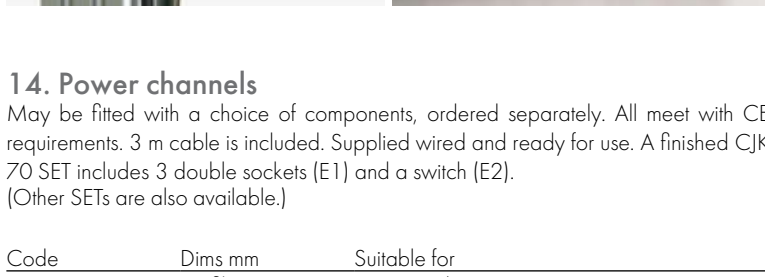

14. Power channels

May be fitted with a choice of components, ordered separately. All meet with CE requirements. 3 m cable is included. Supplied wired and ready for use. A finished CJK 70 SET includes 3 double sockets (E1) and a switch (E2). (Other SETs are also available.)

Code	Dims mm	Suitable for
CJK 70	profile 631	WB 815/818
CJK 100	profile 931	WB 811/818
CJK 70 SET	3 double sockets (E1) and a switch (E2)	

COMPONENTS

E1	Double socket
E2	Switch
E3	Automatic fuse 10 A
E4	Automatic fuse/earth leakage switch 10 A/30 mA
E5	Emergency-stop-switch
E6	Data connector/shielded for Cat.6 cable
E7	Data connector/without screen for Cat.5 cable
E8	Pneumatic, quick coupling 3/8"

workbenches TP/TPH/SAP



Stepless height adjustment with allen-key between 650...900 mm

Designed for use in today's production and assembly environments, this definitive modular system, developed over more than 35 years, provides a high quality working environment. Customise your workstation to your own requirements.



There is a large range of workbench accessories available, see page 11.

1. Workbench TP

Height adjustment with allen-key between 650...900 mm. Frames are of epoxy powder coated steel in grey RAL 7045. The worktops are of 25 mm laminated particle board.

2. Workbench TPH

Height adjustment with allen-key between 650...900 mm. Workbench with upright profiles and a laminate shelf, height adjustment between 1080...1550 mm, load capacity 50 kg. Construction as TP. There are a large range of workbench accessories available, see page 11.

3. Moveable bench SAP

Construction as TP. Height adjustment with allen key between 650..900 mm. Swivel castors Ø 100 mm of which two are braked. Load capacity 150 kg. Lower shelf and push handle available separately.

4. Lower shelf AT

For moveable bench.

5. Handle PUSH

For moveable bench.

No.	Code	Worktop mm	Shelf mm	Load capacity static u.d.l.
1	TP 507	500 x 700		150 kg
	TP 510	500 x 1000		150 kg
	TP 515	500 x 1500		150 kg
	TP 710	700 x 1000		300 kg
	TP 712	700 x 1200		300 kg
	TP 715	700 x 1500		300 kg
	TP 718	700 x 1800		300 kg
	TP 915	900 x 1500		300 kg
	TP 918	900 x 1800		300 kg
2	TPH 712	700 x 1200	310 x 1200	300 kg
	TPH 715	700 x 1500	310 x 1500	300 kg
	TPH 718	700 x 1800	310 x 1800	300 kg
	TPH 915	900 x 1500	310 x 1500	300 kg
	TPH 918	900 x 1800	310 x 1800	300 kg
	3	SAP 507	500 x 700	
SAP 710		700 x 1000		150 kg
SAP 715		700 x 1500		150 kg
4	AT 507		500 x 700	40 kg
	AT 710		700 x 1000	40 kg
5	PUSH 50	depth 500		
	PUSH 70	depth 700		



Line and angle extension TP-L/TP-K/TP-KK

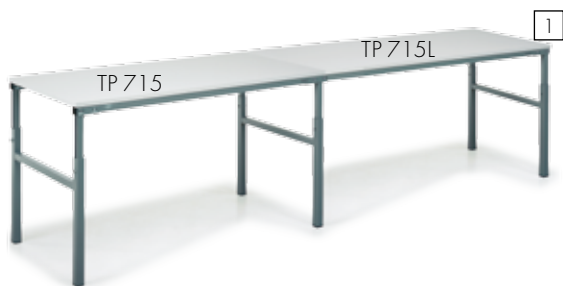

1. Line extension TP - L

Each standard TP-workbench may also be supplied as a line extension. Fitted to side of main bench. Stock sizes are shown.

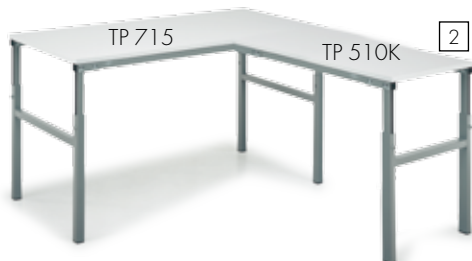

2. Angle extension TP -K

Each standard TP-workbench may also be supplied as an angle extension. Fitted to front angle of main bench. Stock sizes are shown.



3. Corner workbench TP KK

A corner workbench can be used with two TP/TP-K benches (with one H-frame pair) to create a 90 deg. angle setup. This unit consists of a worktop, two side frames and a leg in the middle. Load capacity 150 kg u.d.l. Front side 565 mm.



4. Corner workbench TPH KK

A corner workbench can be used with two TPH benches (with one H-frame pair) to create a 90 deg. angle setup. This unit consists of a worktop and all necessary components. Load capacity 150 kg u.d.l. Front side 565 mm.

No.	Code	Worktop mm	Load capacity*
1	TP 710 L	700 x 1000	150 kg
	TP 712L	700 x 1200	150 kg
	TP 715L	700 x 1500	150 kg
	TP 718L	700 x 1800	150 kg
	TP 915L	900 x 1500	150 kg
	TP 918L	900 x 1800	150 kg
2	TP 510K	500 x 1000	150 kg
	TP 712K	700 x 1200	150 kg
3	TP 707 KK	1100 x 1100	150 kg
	TP 909 KK	1300 x 1300	150 kg
4	TPH 707 KK	1100 x 1100	150 kg
	TPH 909 KK	1300 x 1300	150 kg

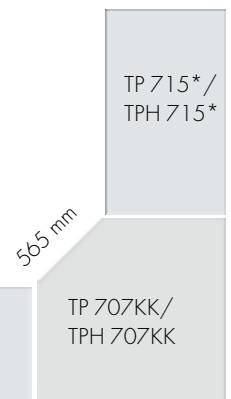

*) Workbench with one H-frame pair **) Load capacity 150 kg u.d.l.

accessories for TPH workbench

Our modular workbench system is versatile and robust. It is easy to customise and adapt to future needs. You can choose from the examples below or build your own.



Assembly workstation

- 1 pcs workbench TPH 715
- 1 pcs tool and lighting support KT 150
- 1 pcs extra C-profile SPR 150
- 1 pcs overlight OL 254
- 1 pcs metal shelf TH 150
- 1 pcs cable channel TJK 150
- 1 x double socket E1
- 1 x switch E2
- 1 pcs steel cabinet ML 02



Service workstation

- 1 pcs workbench TPH 715
- 1 pcs tool and lighting support KT 150
- 1 pcs extra C-profile SPR 150
- 1 pcs overlight OL 254
- 1 pcs perforated panel RL 150
- 1 pcs panel hooks RK 1
- 1 pcs steel cabinet ML 03



Computer workstation

- 1 pcs workbench TPH 715
- 1 pcs cable channel TJK 150
- 2 x double socket E1
- 1 x switch E2
- 1 x automatic fuse E3
- 1 pcs keyboard shelf NT 500 ESD
- 1 pcs PC holder CPU
- 1 pcs LCD arm MA



Universal workstation

- 1 pcs workbench TPH 715
- 1 pcs steel cabinet ML 01



Workbench with shelf TPH

Frames are of epoxy powder coated steel in grey RAL7045. The worktops are of 25 mm laminated particle board.

Code	Worktop D x W mm	Shelf D x W mm	Load capacity u.d.l.
TPH 712	700 x 1200	310 x 1200	300 kg
TPH 715	700 x 1500	310 x 1500	300 kg
TPH 718	700 x 1800	310 x 1800	300 kg
TPH 915	900 x 1500	310 x 1500	300 kg
TPH 918	900 x 1800	310 x 1800	300 kg

Accessories

Accessories are mounted on the uprights of the TPH workbenches. Steel parts are epoxy powder coated in light grey RAL 7035. The shelves are 25 mm laminated particle board

1. Metal shelf TH

Adjustment for depth, height and angle. For stacking and picking bins. Load capacity 30 kg.

2. Bin profile BP

Aluminium profile for stacking and picking bins.

3. Auxiliary shelf SH

Height adjustable shelf. 25 mm laminated particle board.

4. Perforated panel RL

Robust, perforated steel panel. 9 mm perforations at 38 mm centres. Mount on TPH-benches with connectors RK 1. Can also be attached to a wall with screws (included). Panel hooks, pages 22-23.

5. Tool and lighting support KT

For suspending power tools and lighting units. Includes one C-profile bar with sliding hook. Accessory: extra bar.

6. Cable tidy TPHCT

Mounted between C-profiles below worktop. Of perforated epoxy powder coated steel.

7. Swivel arm with tray CKV

Swivel arm with lockable, angle adjustable steel tray. Load 15 kg. Mount on C-profile.

8. Cable clip set CC

The cable clip set will hold cables etc. securely and neatly in place along the bench frame. The clips locate in the 12 mm profile slot.

9. Power channel TJK

May be fitted with a choice of components, ordered separately. 3 m cable is included.

The finished TJK 150 SET and TJK 180 SET include 3 double sockets (E1) and a switch (E2). (Other SETs are also available.)

10. Upright profiles HKCP

If you mount both perforated panel RL and cable channel TJK to TPH benches, you must order an extra-high upright profiles.

Height 1470 mm.

Other Accessories

ML steel cabinets, see page 14

LMC steel cabinets, see page 19

Lighting, see pages 20-21



No..	Code	Dimensions D x W x H mm	Load capacity	Suitability
1	TH 120	145 x 1119	30 kg	TPH 712
	TH 150	145 x 1419	30 kg	TPH 715/915
	TH 180	145 x 1719	30 kg	TPH 718/918
2	BP 120	profil 1115	15 kg	TPH 712
	BP 150	profil 1415	15 kg	TPH 715/915
	BP 180	profil 1715	15 kg	TPH 718/918
3	SH 150	310 x 1500	50 kg	TPH 715/915
	SH 180	310 x 1800	50 kg	TPH 718/918
4	RL 120	750 x 1115		TPH 712
	RL 150	750 x 1415		TPH 715/915
	RL 180	750 x 1715		TPH 718/918
	RK 1	Panel hooks for TPH		TPH
5	KT 120	600 x 1200		TPH 712
	KT 150	600 x 1500		TPH 715/915
	KT 180	600 x 1800		TPH 718/918
	Extra bar			
	SPR 150	1500		KT 150
6	TPHCT 120	45 x 205 x 1115		TPH 712
	TPHCT 150	45 x 205 x 1415		TPH 715/915
	TPHCT 180	45 x 205 x 1715		TPH 718/918
7	CKV 400	tray 210 x 460	15 kg	TPH
8	CC 12	5 pcs/set		TPH
9	TJK 120	profil 1058		TPH 712
	TJK 150	profil 1358		TPH 715/915
	TJK 180	profil 1658		TPH 718/918
	TJK 150 SET	includes 3 x E1, E2		TPH 715/915
	TJK 180 SET	includes 3 x E1, E2		TPH 718/918
	Components			
	E1	Double socket		
E2	Switch			
E3	Automatic fuse 10 A			
E4	Automatic fuse /earth leakage switch 10 A/30 mA			
E5	Emergency-stop-switch			
E6	Data connector/shielded for Cat.6			
E7	Data connector/without screen for Cat.5			
E8	Pneumatic, quick coupling 3/8"			
10	HKCP	height 1470 mm		TPH

heavy duty workbenches HDB/HDBL



Heavy duty trolley RV 608

Frames are of epoxy powder coated steel in two tone grey: light grey RAL 7035 and grey RAL 7045. Worktop of steel with fluted rubber mat. Four castors Ø 125 mm, two with brakes. Handle. Load capacity 300 kg. Dimensions D x W x H: 600 x 767 x 845 mm



Heavy duty workbenches

Heavy duty workbenches for production and assembly areas, service centres and workshops. Benefits: robust construction, modern design and versatile accessories. Bracing panel for additional stability and lipped back edge; also acts as attachment point for vertical posts. Frames are of epoxy powder coated steel in grey RAL 7045. Worktop height is 845 mm. Three top choices

- S= zinc plated steel on particle board. Worktop thickness 42 mm. Load capacity 750 kg.
- P= PVC laminated particle board. Thickness 40 mm. Load capacity 500 kg.
- W= birch plywood. Thickness 40 mm. Load 750 kg.



HDB

This unit consists of worktop, bracing panel and 2 leg frames.

Code	Dims mm	Worktop	Load capacity
HDB 715S	750 x 1500	steel	750 kg
HDB 715P		PVC	500 kg
HDB 715W		birch	750 kg
HDB 718S	750 x 1800	steel	750 kg
HDB 718P		PVC	500 kg
HDB 718W		birch	750 kg



HDBL - ML

This unit consists of worktop, bracing panel and 1 leg frame. Worktop height is 845 mm. The left or right leg frame will be replaced with a steel cabinet ML 06 which is ordered separately. Cover MLS needed for mounting. Cabinet, see page 14.

Workbench with right leg frame	Workbench with left leg frame	Dims mm	Worktop
HDBL 715S-R	HDBL 715S-L	750 x 1500	steel
HDBL 715P-R	HDBL 715P-L		PVC
HDBL 715W-R	HDBL 715W-L		birch
HDBL 718S-R	HDBL 718S-L	750 x 1800	steel
HDBL 718P-R	HDBL 718P-L		PVC
HDBL 718W-R	HDBL 718W-L		birch

HDBL - S

This unit consists of worktop, bracing panel and 1 leg frame. Worktop height is 845 mm. The left or right leg frame will be replaced with a steel cabinet 612 35 204 which is ordered separately. Cabinet, see page 16.

Workbench with right leg frame	Workbench with left leg frame	Dims mm	Worktop
HDBL 715S-R-S	HDBL 715S-L-S	750 x 1500	steel
HDBL 715P-R-S	HDBL 715P-L-S		PVC
HDBL 715W-R-S	HDBL 715W-L-S		birch
HDBL 718S-R-S	HDBL 718S-L-S	750 x 1800	steel
HDBL 718P-R-S	HDBL 718P-L-S		PVC
HDBL 718W-R-S	HDBL 718W-L-S		birch



1. Frame HF

Needed for mounting accessories to benches. Includes 3 vertical aluminium profiles and 1 horizontal steel profile.

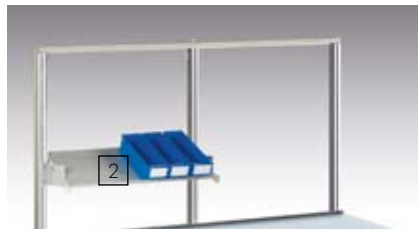

2. Steel shelf HSS

Adjustment for depth, height and angle. With retaining lip, rear or front mounting.



3. Bin profile BP

Height adjustable aluminium bin rail, to hold Treston stacking and picking bin

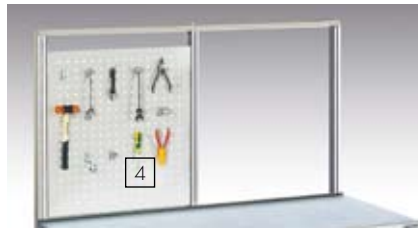

4. Perforated panel HPP

Steel panel. 9 mm perforations at 38 mm centres. Panel hooks, pages 22 - 23.



5. Cupboard unit HCU

Constructed of perforated steel: 9 mm perforations at 38 mm centres. Lock, steel shelf and connectors as standard. Dimensions 310 x 687 x 700 mm.



6. Support bracket HSB

For suspending power tools and lighting units. Includes one bar with sliding hook and second bar for lighting units.



7. Lower shelf HLS

Steel lower shelf in two parts. Can be used as one part shelf too. Load capacity 100 kg static u.d.l.

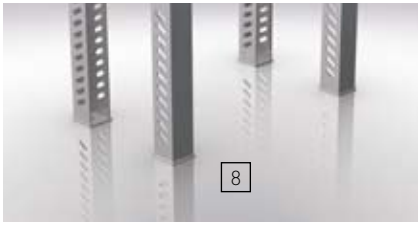

8. Height adjustment kit HAK

Allows height adjustment to be made in 25 mm increments between 845 - 1095 mm.



9. Cable channel CJK

May be fitted with a choice of components, ordered separately. All meet with CE requirements. 3 m cable is included. Supplied wired and ready for use. A finished CJK 70 SET includes 3 double sockets (E1) and a switch (E2). (Other SETs are also available.)

No	Code	Dims D x W x H mm	Load	Suitable for
1	HF 150	692 + 692		HDB/HDBL 715
	HF 180	692 + 992		HDB/HDBL 718
2	HSS 73	310 x 686	15 kg	HDB/HDBL 715 HDB/HDBL 718
	HSS 103	310 x 986	15 kg	HDB/HDBL 718
3	BP 70	profile 685	15 kg	HDB/HDBL 715 HDB/HDBL 718
	BP 100	profile 985	15 kg	HDB/HDBL 718
4	HPP 73	686 x 750		HDB/HDBL 715 HDB/HDBL 718
	HPP 103	986 x 750		HDB/HDBL 718
5	HCU73	310 x 687 x 700		HDB/HDBL 715 HDB/HDBL 718
6	HSB 150	1500		HDB/HDBL 715
	HSB 180	1800		HDB/HDBL 718
7	HLS 515	500 x 1500	100 kg	HDB 715
	HLS 518	500 x 1800	100 kg	HDB 718
8	HAK	4 pcs/set		HDB
9	CJK 70	profile 631		HDB/HDBL 715 HDB/HDBL 718
	CJK 100	profile 931		HDB/HDBL 718
	CJK 70 SET	profile 631	includes 3 x E1, 1 x E2	HDB/HDBL 715 HDB/HDBL 718

COMPONENTS

E1	Double socket
E1 GB	Single socket
E2 GB	Switched single socket
E2	Switch
E3	Automatic fuse 10 A
E4	Automatic fuse/earth leakage switch 10 A/30 mA
E5	Emergency-stop-switch
E6	Data connector/shielded for Cat.6 cable
E7	Data connector/without screen for Cat.5 cable
E8	Pneumatic, quick coupling 3/8"

metal cabinets ML



Cabinet ML 04 includes fluted rubber mat on top, handle and 4 castors Ø 100 mm, 2 with brakes

Drawer	
Outer height mm	inner height mm
60	50
120	110
140	130
180	170
360	350

Centrally locked high quality steel cabinets for storage of tools and small components. Mounted under workbenches with brackets (included). One model available with wheels as an independent tool trolley. Six size alternatives. Steel cabinets are epoxy powder coated in grey paint, RAL7045. Central locking. Full width drawer handle in anodised aluminium. Smooth and quiet telescopic ball-race runners and clear opening of 405 mm. Load capacity 35 kg/drawer. Drawer size 500 x 406 mm.

Suitability

- For TP/TPH/SAP benches of 700 mm depth and over, all cabinets are suitable. Mounting brackets for these benches are included.
- For HDB/HDBL benches all cabinets are suitable. Cover MLS needed for mounting, ordered separately.
- For VWB benches we recommend cabinets ML 01 and ML 02. Cover MLS needed for mounting, ordered separately.

Dividers MLX 1

Includes 7 fixed compartments. Height 50 mm.

Dividers MLX 2/50

Includes a frame, 3 longitudinal dividers and 15 internal dividers. Height 38 mm. Galvanised steel.







Dividers MLX 2/100

Includes a frame, 3 longitudinal dividers and 15 internal dividers. Height 68 mm. Galvanised steel.

Cover MLS

Needed for mounting cabinets to WB/HDB/HDBL benches.



	Code	Includes drawers Outer height mm	Outer dims D x L x H mm
	ML 01	1 x 140	580 x 453 x 142
	ML 02	1 x 60 2 x 120	580 x 490 x 351
	ML 03	1 x 60 2 x 120 1 x 180	580 x 490 x 532
	ML 04	1 x 60 2 x 120 1 x 180 + top, handle and 4 castors	580 x 490 x 670
	ML 05	1 x 120 1 x 360	580 x 490 x 532
	ML 06	1 x 60 3 x 120 1 x 180 + plinth, H = 110 mm	580 x 490 x 762

drawer cabinets

With these Drawer Cabinet systems, safety plays a vital role

NEW



The drawer unit can be moved with a pallet truck or a forklift when the plinth front plate has been removed.

With these Drawer Cabinet systems, safety plays a vital role. The safety locking device ensures that only one drawer at a time can be opened and thus prevents cabinets from tipping. The central locking system prevents unauthorised access. Available in two cabinet sizes: 1100 mm, 1400 mm high. The 1100 mm high drawer units with plinth include a reinforced cover that doubles as a worktop with a fluted rubber mat. This is the ideal height to work standing up.

The drawer unit can be moved with a pallet truck or a forklift when the plinth front plate has been removed. The drawers are 85% extendable and their load capacity is 80 kg. Steel cabinets are epoxy powder coated in light grey paint, RAL 7038. Accessories: drawer dividers, see page 17.

Product	Code	Outer dims D x L x H mm	Drawers		
			Inner dims mm	Pcsr x height mm	Load capacity kg
Drawer cabinet includes a plinth and a reinforced cover that doubles as a worktop with a fluted rubber mat.	613 35 005	715 x 715 x 1100	612 x 612	2 x 50	80
				1 x 100	80
				3 x 150	80
				1 x 250	80
Drawer cabinet includes a plinth.	616 35 007	715 x 715 x 1400	612 x 612	1 x 50	80
				4 x 75	80
				3 x 100	80
				2 x 150	80
				1 x 250	80

550 mm wide drawer cabinets

NEW



Drawer unit with plinth can serve as legs to support one end of worktop. The 50 mm high drawer is fully extendable with a load capacity of 40 kg. The other drawers are 85% extendable with a load capacity of 80 kg. The mobile unit is fitted with 4 castors D100 mm, 2 with brakes. Load capacity 300 kg. Steel cabinets are epoxy powder coated in light grey paint, RAL 7038. Accessories: drawer dividers, see page 17.



Drawer units with plinth 612 35 204 also serve as workbench legs

Product	Code	Outer dims D x L x H mm	Drawers		
			Inner dims mm	pcs x height mm	Load capacity kg
Drawer cabinet	612 35 204	715 x 550 x 800	612 x 460	2 x 50 1 x 100 1 x 150 1 x 250	40 80 80 80
Mobile drawer cabinet: includes 4 castors, D100 mm and cover with a rubber mat.	612 35 304	715 x 550 x 800	612 x 460	2 x 50 1 x 100 1 x 150 1 x 250	40 80 80 80 80

dividers for drawer cabinets

Suitable for drawer size 612 x 612 mm

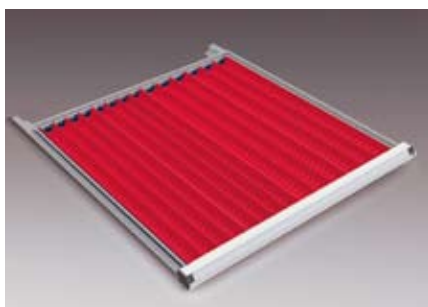

Drawer compartments

Suitable for drawer size 612 x 612 mm.
ABS plastic, colour red.

Includes:

- 8 tool troughs, width 33 mm
- 8 tool troughs, width 45 mm
- 20 dividers 33 mm
- 20 dividers 45 mm

Suitable for drawer height	Code
50 - 75 mm	837 911-00

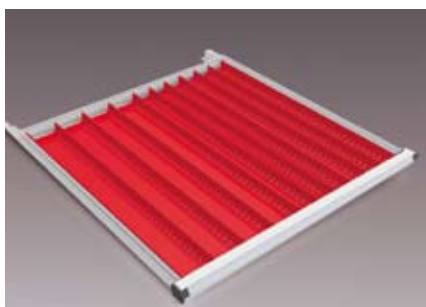

Drawer compartments

Suitable for drawer size 612 x 612 mm.
ABS plastic, colour red.

Includes:

- 8 tool troughs, width 45 mm
- 8 tool troughs, width 70 mm
- 20 dividers 45 mm
- 10 dividers 70 mm

Suitable for drawer height	Code
50 - 75 mm	837 938-00



Drawer compartments

Suitable for drawer size 612 x 612 mm.
Longitudinal dividers and internal dividers are of light grey epoxy powder coated steel. Can be used to create custom compartments.

Includes:

- 3 longitudinal dividers 610 mm
- 6 internal dividers 100 mm
- 6 internal dividers 150 mm
- 2 internal dividers 300 mm

Suitable for drawer height	Code
50 mm	837 954-35
75 mm	838 300-35
100 - 125 mm	837 989-35
50 - 250 mm	838 004-35

Suitable for drawer size 612 x 460 mm

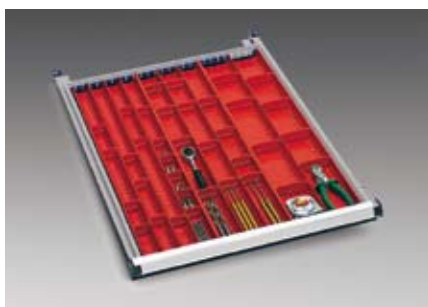

Drawer compartments

Suitable for drawer size 612 x 460 mm.
ABS plastic, colour red.

Includes:

- 4 tool troughs, width 33 mm
- 4 tool troughs, width 45 mm
- 4 tool troughs, width 70 mm
- 10 dividers 33 mm
- 10 dividers 45 mm
- 10 dividers 70 mm

Suitable for drawer height	Code
50 mm	834 122-00



Drawer compartments

Suitable for drawer size 612 x 460 mm.
Longitudinal dividers and internal dividers are of light grey epoxy powder coated steel. Can be used to create custom compartments.

Includes:

- 3 longitudinal dividers 610 mm
- 6 internal dividers 100 mm
- 6 internal dividers 150 mm

Suitable for drawer height	Code
50 mm	834 114-35
100 mm	834 203-35
150 - 250 mm	834 262-35



shelf cabinets HKS



Shelf cabinet HKS 100/200 ESD

High-quality shelf cabinet is made of semiconductive epoxy powder coated, profiled steel, light grey RAL 7038. Standard fittings: cabinet lock with two keys, sturdy double leaf-doors, 2 or 4 shelves, 4 pcs adjustable feet and cabinet base of steel. The robust base is welded together. The cabinet unit can be moved with a pallet truck or a forklift when the plinth front plate has been removed. This product is flat packed in an individual carton with all necessary fittings and instructions.

Code	Shelves number	Dimensions	Max. load/shelf kg	Max. load/cabinet kg
HKS 100 ESD	2	435 x 835 x 997	100	300
HKS 200 ESD	4	435 x 835 x 2000	100	300

Extra shelf HS 48 ESD

Size 396 x 786 x 32 mm. Max. load 100 kg.
Semiconductive epoxy powder coated steel, light grey RAL 7038.

Perforated panel RLHKS 48

Size 783 x 500 mm.
Semiconductive epoxy powder coated steel, light grey RAL 7038.

Drawer HSV 48 ESD

Outer dims D x W x H: 394 x 744 x 107 mm.
Inner dims D x W x H: 346 x 721 x 89 mm
Max. load 30 kg. The drawer is extendable 100%. Semiconductive epoxy powder coated steel, light grey RAL 7038.

NEW

light shelf cabinets HK

Shelf cabinets HK 100/180

Designed for use in light storage. This cabinet is flat packed in an individual carton with all necessary fittings and instructions. Steel cabinets are epoxy powder coated in light grey. The shelves can be adjusted on 50 mm centres. Standard fittings: Locking bar system, steel double doors, 2 or 3 shelves and cabinet base.

Code	Shelves	Dimensions D x W x H mm	Max. load/ shelf kg	Max. load/ cabinet kg
HK 100 ESD	2	460 x 915 x 1015	50	150
HK 180 ESD	3	460 x 915 x 1830	50	200

Extra shelf H 49 K ESD

Size 385 x 910 mm.

Perforated panel RLHK 49

Size 880 x 550 mm. Epoxy powder coated steel, light grey RAL 7035.



light steel cabinets LMC







Steel cabinets LMC

These updated steel cabinets are an ideal way of providing individual secure storage for your staff. Drawers mounted on telescopic ball race slides. Four new cabinet sizes, including one drawer/cupboard combination. These cabinets suit any Treston workbench. The cabinet frames are epoxy powder coated steel; drawer fronts are composite board with aluminium handles. Colour light grey, RAL 7035. Load capacity is 15 kg per drawer. Mount on benches with brackets (included). Outer height of the drawer 100 mm, inner dimensions D x L : 425 x 302 mm.

Suitable for
WB/TP/TPH workbenches
SAP 710/SAP 715/WTR trolleys

Cover LMCK2

Needed for mounting cabinets to WB benches and WTR trolley..

	Code	Includes drawers Outer height mm	Outer dims D x L x H mm
	LMC 01	1 x 100	460 x 370 x 140
	LMC 02	2 x 100	460 x 370 x 245
	LMC04	4 x 100	460 x 370 x 455
	LMC04D	1 x 100 + + cupboard, height 300 mm, open to right	460 x 370 x 455

power channels

Power channel CJK/WJK/TJK/PJK

Constructed from aluminium profile, this range of compact power channels provides power distribution for our benches and workstations. Pre-assembled with a choice of components, ordered separately. Power channel is isolated from the workbench. 3 m cable is included. Aluminium profile 72 x 72 mm All meet with CE requirements.

Outlet panel PRK 5

Outlet panel has 5 Schuco wall sockets, switch and 3 m cable. Mount on upright profile of TRESTON-benches WB/TP/TPH and trolley CTR/SAP/WTR with connectors (included). Can also be attached under the laminate shelf with screws.



Panel	Profile length	Suitable for
CJK 70	631 mm	WB 815/818/ HDB 715/718
CJK 100	931 mm	WB 811/818/ HDB/HDBL 718
WJK 40	470 mm	WTR 140
TJK 120	1058 mm	TPH 712
TJK 150	1358 mm	TPH 715/915
TJK 180	1658 mm	TPH 718/918
PJK 70	640 mm	P 0712/0720
PJK 100	640 mm	P 1012/1020
CJK 70 SET	include 3 double sockets (E1) and switch (E2)	WB 815/818/ HDB 715/718
TJK 150 SET		TPH 715/915
TJK 180 SET		TPH 718/918

COMPONENTS	
E1	Double socket
E2	Switch
E3	Automatic fuse 10 A
E4	Automatic fuse/ earth leakage switch 10 A/30 mA
E5	Emergency-stop-switch
E6	Data connector/shielded for Cat.6 cable
E7	Data connector/without screen for Cat.5
E8	Pneumatic, quick coupling 3/8"

led magnifying task light



The magnifying task light is suitable for precise work for professionals in industry, research and development, laboratories, the medical profession, precision crafts, beauty clinics, the visually impaired etc.

Graph of light intensity

Work surface dimensions: 60 x 60 cm. Distance of light from surface: 20 cm and 50 cm. Unit of measure: lux (lx). The higher the number, the stronger the light.

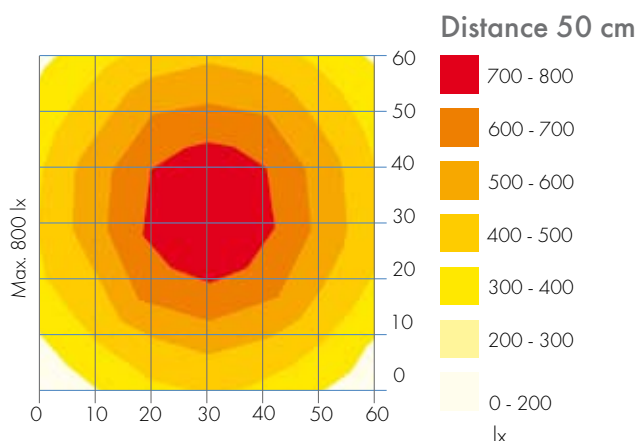
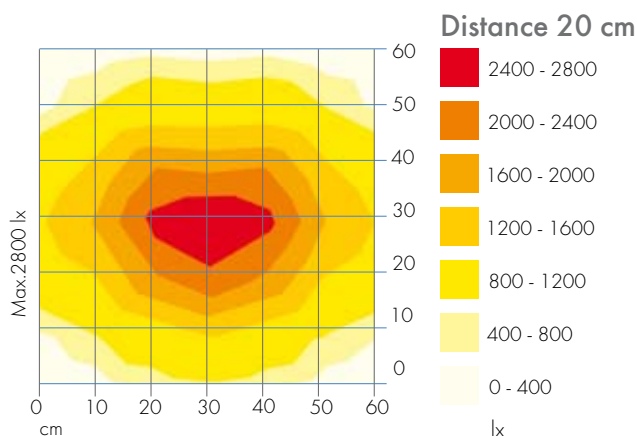

Magnifying light ZL3

The new technology led light creates the same amount of bright, flicker free light as a comparative fluorescent light but saves up to 75% electricity. The light has a 3 dioptr magnifying glass and an easy to use multi joint arm to be connected to a bench top.

Light is produced by 6 powerful leds that can be adjusted according to needs; the left and right sides can be independently adjusted in steps. The light has a last-setting memory and the original settings can be reset. Environmentally friendly and long life leds do not flicker or react to bumps and vibrations

Technical specifications

Led-lights:	6 led-lights, 3 on either side of lens.
Light intensity:	max. 2800 lx (lux)
Colour temperature:	6000 K (Kelvin)
Power:	80 lm/W (lumens/watt)
Voltage:	230 V
Dimmer:	0-100%, left and right sides dimmable separately in steps (11 steps)
Colour rendering index:	70 cri
Lens diameter:	Ø 127 mm
Magnification:	175% =3-dioptre lens
Special function:	Last setting remains in memory, until settings are changed.
Construction:	anodised aluminium, glass and UV-stabilised polycarbonate
Attachment:	sturdy table clamp, 18- 70 mm
Support arm:	length about 850 mm
Standard equipment:	2 metre cord with Schuco plug / BS plug
Ingress Protection Rating:	IP 44
Temperature range:	10 - 40°C

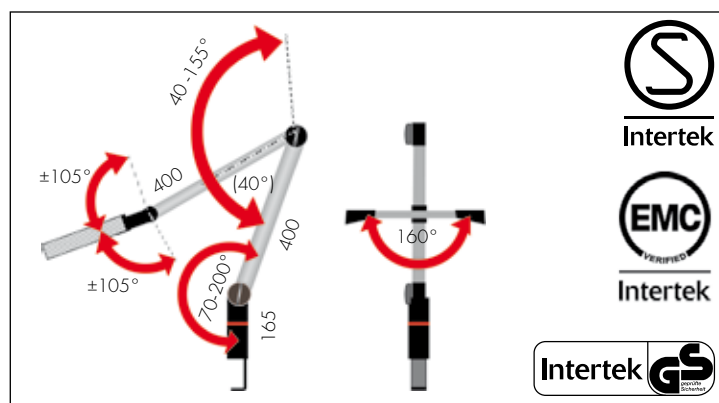

lighting units



Lighting is an essential part of workstation ergonomics, as well designed lighting aids industrial safety, comfort and productivity. Particular applications need both sidelights and overhead. This system provides the best possible illumination. Quick, flicker-free electronic light ignition and vibrationless operation. Light output unaffected by fluctuations in voltage. Suitable for use with moving machinery giving asymmetric lighting with minimal shadow. (Flicker free tubes ensure that rotating objects will not appear to be stationary, a common optical effect when standard fluorescent tubes are used.)

Silver grey anodized aluminium frame with a matte anti-dazzle screen. Angle continuously adjustable. With own switch and 3 m cable. The lighting units are isolated from the workbench.



Overlight OL 254

2 x 5T fluorescent tubes: 54W
 Length: 1200 mm
 Enclosure class: IP 20
 Suitability: WB/TPH/HDB/HDBL
 Mount on support bracket

Overlight with dimmer OL 254 D

As OL 254, but with a dimmer.

Sidelight SL 224

2 x 5T fluorescent tubes: 24W
 Length: 590 mm
 Length: 590 mm
 Suitability: WB/TPH/HDB/HDBL
 Mounting kit SL-HKC required for use with TPH benches; ordered separately.

Graph of light intensity

Light intensity (lux) is tested on a horizontal worktop using the OL 254. The diagram below shows the results. Worktop size is 700 x 1500 mm, height of light unit above worktop is 1000 mm. The lux (lx) is the SI unit of illuminance and luminous emittance measuring luminous power per area.

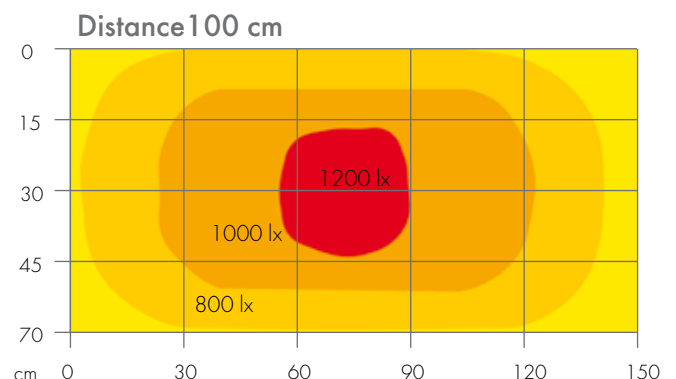

panel hooks

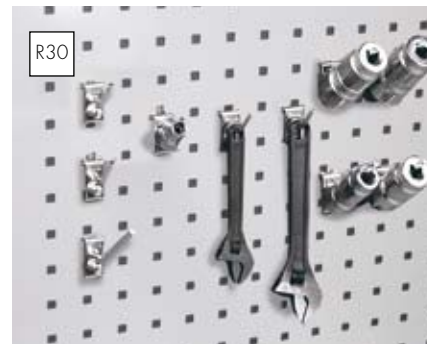
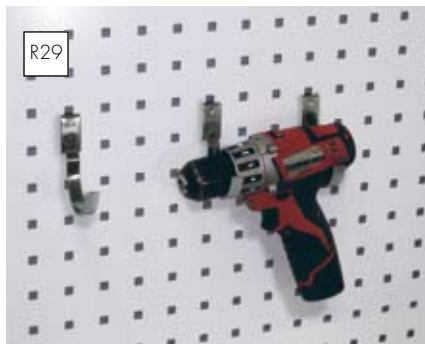
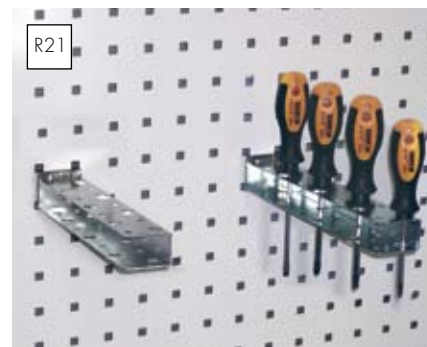
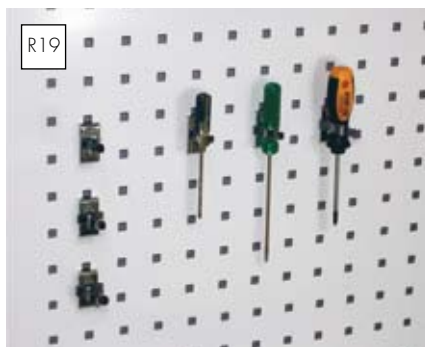
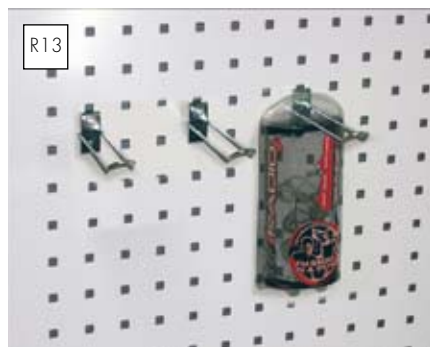
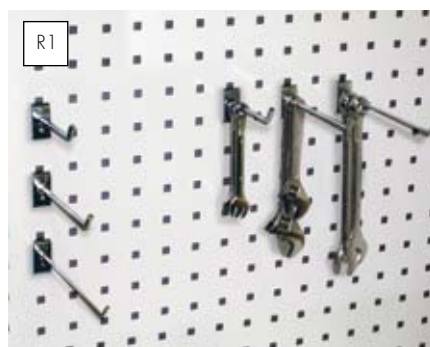

Panel hooks

Our range of panel hooks fits TRESTON perforated panels as well as many other common panel types. All hooks are zinc-plated steel with locking screws.

Type	Product	Code	Dimensions mm	Steel wire Ø mm	Distance mm	Load kg	Pack pcs
R 1	Universal hook	R1-030	length 30	3		10	5
		R1-080	length 80	6		20	5
		R1-100	length 100	6		15	5
		R1-150	length 150	6		10	5
		R1-200	length 200	6		6	5
R 2	Double hook	R2-043	length 43	4	25	15	5
		R2-100	length 100	6	25	15	5
		R2-150	length 150	6	25	15	5
R 3	Right-angle hook	R3-010	length 10	6		20	5
		R3-050	length 50	6		20	5
R 13	Package hook	R13-157	length 157	3		1	5
R 19	Spring clip	R19-013	Ø 13				5
		R19-019	Ø 19				5
		R19-022	Ø 22				5
R 21	Chisel shelf	R21-220	length 220	hole Ø 12			1
R 24	Tubular cup	R24-080	height 80	cup Ø 26			1
R 29	Power tool hook	R29-060	length 60			5	5
R 30	Slanted hook	R30-035	length 35	4		20	5
		R30-085	length 85	6		20	5

panel hooks and perforated panels

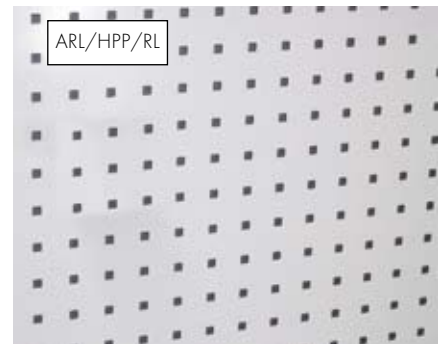
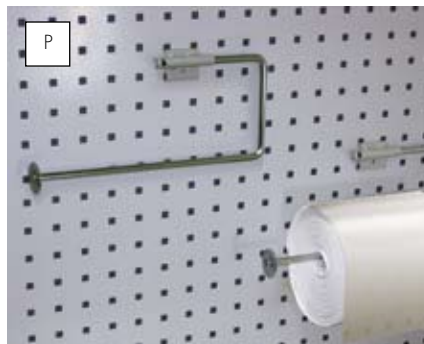
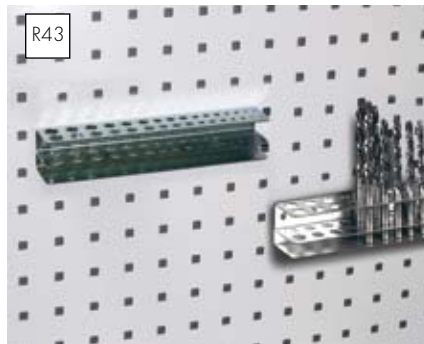
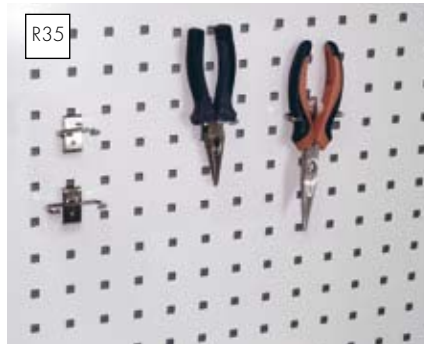

Type	Product	Code	Dimensions mm	Distance mm	Load kg	Pack pcs
R 33	Round cup	R33-030	height 30	cup Ø 90		1
R 35	Pliers hook	R35-035	length 17	35		5
		R35-055	length 17	55		5
R 37	Circle hook	R37-060		circle Ø 60	20	1
R 41	Hook rail	R41-556	length 556			1
R 43	Drill shelf	R43-238	length 238			1
R 46	Bin rail	R46-112	length 112, for stacking and picking bins			1
R 47	Steel shelf	R47-350	D x W: 120 x 350		4	1
P	Paper roll hook	P 300	max roll 300			1

Hook R 20 SET

- 5 pcs R 1 Universal hook, length 50 mm
- 5 pcs R 2 Double hook, length 33 mm
- 5 pcs R 19 Spring clip, length Ø 19 mm
- 5 pcs R 30 Slanted hook, length 35 mm

Hook R 45 SET

- 5 pcs R 1 Universal hook, length 30 mm
- 5 pcs R 1 Universal hook, length 50 mm
- 5 pcs R 2 Double hook, length 33 mm
- 5 pcs R 19 Spring clip, Ø 19 mm
- 5 pcs R 19 Spring clip, Ø 22 mm
- 1 pcs R 21 Chisel shelf, length 220 mm
- 1 pcs R 24 Tubular cup Ø 26 mm, height 80 mm
- 5 pcs R 29 Power tool hook, length 60 mm
- 5 pcs R 30 Slanted hook, length 35 mm
- 1 pcs R 33 Round cup Ø 90 mm, height 30 mm
- 5 pcs R 35 Pliers hook, length 17 mm, distance 35 mm
- 1 pcs R 37 Circle hook, Ø 60 mm
- 1 pcs R 42 Chisel shelf, length 238 mm

Perforated panels ARL/HPP/RL

Perforated panels with 9 mm perforations at 38 mm centres. Epoxy powder coated steel in light grey RAL 7035.

Code	Dims mm	Suitable for
ARL 70	500 x 670	WB 815/818
ARL 100	500 x 970	WB 811/818
HPP 73	686 x 750	HDB/HDBL 715/718/IT 170
HPP 103	986 x 750	HDB/HDBL 718/HAT 610
RL 120	750 x 1119	TPH 712/wall mounting
RL 150	750 x 1419	TPH 715/915/wall mounting
RL 180	750 x 1719	TPH 718/918/wall mounting
RK 1	Connectors	Needed for mounting panels to TPH benches

computer accessories

Keyboard shelf NT 500 ESD

A pull-out keyboard shelf with integral wrist support and mouse pad to mount underneath the bench worktop. Outer dims D x L x H 250 x 500 x 110 mm. Suitable for WB/TP/TPH- workbenches and SAP/WTR- trolleys.



NT 500 ESD

PC stand CPU

An adjustable holder for either vertical or horizontal CPU, to mount underneath the bench worktop. Suitable for WB/TP/TPH benches and SAP/CTR/WTR trolleys. Suitable for WB/TP/TPH workbenches and SAP/CTR/WTR trolleys.

Width	Height
130...240 mm	395...500 mm
340...460 mm	180...285 mm



CPU

LCD bracket MH

Max load 15 kgs. The quick-release mechanism is equipped with the standard, widely used flat-screen mount 75 x 75 and 100 x 100 for the mounting of all normal flat-screens. Suitable for WB/TPH benches and WTR trolley. Connector HKC-MH/MA needed for mounting LCD bracket MH to TPH benches, ordered separately.

LCD swivel arm MA

Max load 10 kgs. The quick-release mechanism is equipped with the standard, widely used flat-screen mount 75 x 75 and 100 x 100 for the mounting of all normal flat-screens. The arm is double articulated, turns through a radius of 180° and will extend between 95-425 mm from the upright. Suitable for WB/TPH benches and WTR trolley. Connector HKC-MH/MA needed for mounting LCD swivel arm MA to TPH benches, ordered separately.

LCD swivel arm MA 2

Max load 15 kgs. The quick-release mechanism is equipped with the standard, widely used flat-screen mount 75 x 75 and 100 x 100 for the mounting of all normal flat-screens. The arm is double articulated, turns through a radius of 180° and will extend between 95-425 mm from the upright. Suitable for WB/TPH benches and WTR trolley. Connector HKC-MA2 needed for mounting swivel arm MA2 to TPH benches, ordered separately.

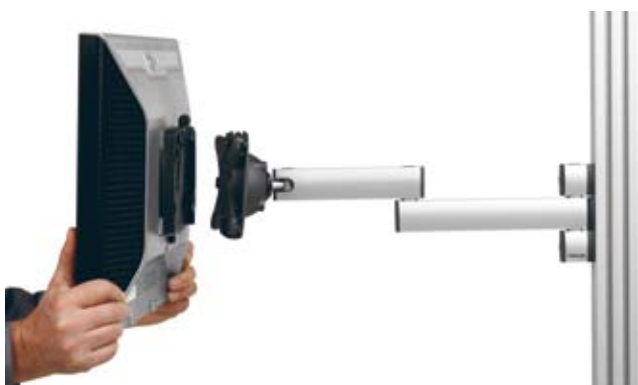

The quick release mechanism is easy and quick to use



MH

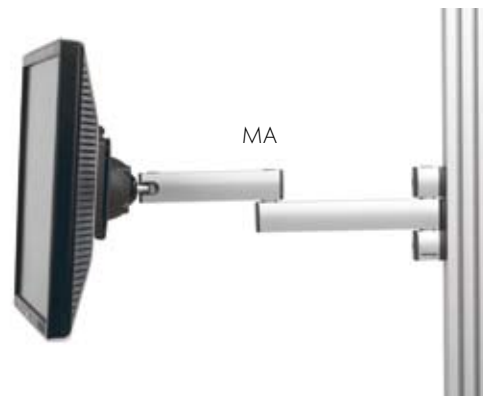

MA

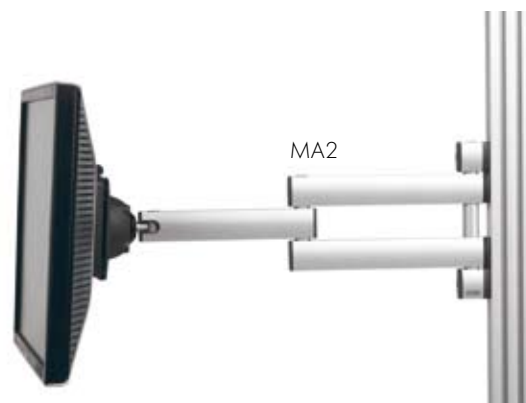

MA2

other accessories

Bottle holder CH

Practical holder for bottle or cup. Made of black polypropylene. Inside diameter 80 mm. Outside dimensions: D x W x H: 110 x 105 x 120 mm. Suitable for AL2X and WTR profile.



universal trolley WTR

A good quality, versatile trolley, PC-station, measuring station or mobile storage. Modern industrial design.

1. Universal trolley WTR 140

Standard trolley has 3 shelves (TS 605), size 650 x 530 mm. Height adjustment of shelves by allen-key. The vertical profiles are of aluminium. Frames are of epoxy powder coated steel: light grey RAL 7035. The worktops are of 25 mm laminated particle board. Four swivel castors Ø 125 mm of which two are braked, overall height of castor 141 mm. Load capacity 150 kg. Outer dimensions D x W x H: 650 x 650 x 1415 mm.

2. Extra shelf TS 605

Shelf of 25 mm laminated particle board, size 650 x 530 mm. Load capacity 50 kg.

3. Adjustable shelf TAS 605

Continuous adjustment for depth, height and angle. 25 mm laminated particle board, size 650 x 530 mm. Lipped front edge. Load capacity 50 kg.

4. Bin profile BP 50

Aluminium profile for TRESTON stacking and picking bins. Length 525 mm.

5. Power channel WJK 40

May be fitted with a choice of components, ordered separately. All meet with CE requirements. 3 m cable is included. Profile length 470 mm.

COMPONENTS

- E1 Double socket (max. 5 pcs/1 cable)
- E2 Switch
- E3 Automatic fuse 10 A
- E4 Automatic fuse/earth leakage switch 10 A/30 mA
- E5 Emergency-stop-switch
- E6 Data connector/shielded for Cat.6 cable
- E7 Data connector/without screen for Cat.5
- E8 Pneumatic, quick coupling 3/8"

Light steel cabinets, page 19

Keyboard shelf, page 24



adjustable trolleys TRTA

For general use in workshop, office, production areas, hospitals. Height of all shelves can be adjusted by allen-key. Frames are of epoxy powder coated steel in grey (RAL 7045). Shelves 12 mm laminated particle board with steel edging. Four swivel castors Ø 125 mm of which 2 are braked.

2-shelf trolleys

Shelf adjustments between 200...770 mm. Load capacities: max. 150 kg/trolley and max. 50 kg/shelf.

Code	Shelf size	Outer measurements
	D x W mm	D x W x H mm
TRTA 4082	430 x 800	535 x 900 x 1015
TRTA 4102	430 x 1000	535 x 1100 x 1015
TRTA 5082	530 x 800	635 x 900 x 1015
TRTA 5102	530 x 1000	635 x 1100 x 1015

4-shelf trolleys

Shelf adjustments between 215...1340 mm. Load capacities: max. 300 kg/trolley and max. 50 kg/shelf.

Code	Shelf size	Outer measurements
	D x W mm	D x W x H mm
TRTA 4104	430 x 1000	535 x 1100 x 1535
TRTA 5104	530 x 1000	635 x 1100 x 1535

Extra shelf TRHA

Shelves are of 12 mm laminated particle board with steel edging. Load capacity 50 kg.

Code	Shelf size
	D x W mm
TRHA 408	430 x 800
TRHA 410	430 x 1000
TRHA 508	530 x 800
TRHA 510	530 x 1000

End mesh panels NET 2

The mesh panels can be installed at the ends of the trolley or on the sides. An angle bracket is set on the edge of the upper and lower shelf and the mesh is screwed into place. The 4-shelf trolley can hold 2 mesh panels on top of each other. Steel mesh is epoxy coated in grey. Size 364 x 604 mm. One set includes 2 mesh panels.

Document holder DSA4 ESD

Document stand A4. Semiconductive epoxy powder coated steel. Includes two magnets.



industrial trolley IT

A versatile trolley that has been designed for use in light assembly, test and repair areas.

1. Industrial trolley IT 170

Frames are of epoxy powder coated steel in grey RAL 7045, with perforated profiles: adjustment in 39 mm increments. One perforated panel is included with the trolley, size 200 x 685 mm. Bottom shelf of steel with fluted rubber mat. Four castors Ø 125 mm, two with brakes. Load capacity 150 kg. Overall dimensions D x W x H: 625 x 777 x 1725 mm.

2. Steel shelf ISS

Adjustment for height, angle 0...30° and depth 0 - 100 mm. With front retaining lip. Load capacity 40 kg. Two sizes.

Code	Dimensions
ISS 407	400 x 680 mm
ISS 607	600 x 680 mm

3. Perforated panel HPP 73

Perforated panel of epoxy powder coated steel in light grey RAL 7035. 9 mm perforations at 38 mm centres. Size 686 x 750 mm.

4. Bin rail BP 70

Height adjustable aluminium bin rail, to hold Treston stacking and picking bins. Length 685 mm.

5. Cupboard unit HCU 73

Constructed of epoxy powder coated, perforated steel in light grey RAL 7035. 9 mm perforations at 38 mm centres. Lock, steel shelf and connectors as standard. Dimensions D x W x H: 310 x 687 x 700 mm.



Combination in the picture:

- 1 x trolley IT 170
- 2 x shelf ISS 407
- 1 x shelf ISS 607

Combination in the picture:

- 1 x trolley IT 170
- 1 x perforated panel HPP 73
- 1 x bin profile BP 70

Combination in the picture:

- 1 x trolley IT 170
- 1 x shelf ISS 607
- 1 x cupboard unit HCU 73

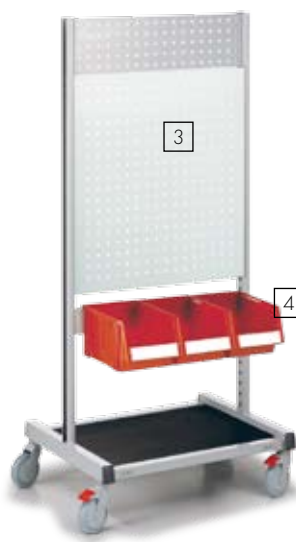
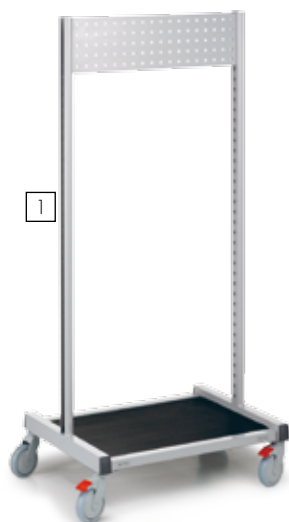

upholstered chairs X

Design Yrjö Kukkapuro & Reijo Raatesalmi



X 30

A gas lift controls height adjustment. Tilt of seat, angle and height of back rest mechanically adjusted. The padding is fireproof foam with a high quality fabric. Swivelling twin castors, which are braked when unloaded, are standard. Upholstery 100 % Polyester. Arm rests optional.

X 32

Construction as X 30, but slightly higher. The height adjustability range and tilting seat makes it possible to work in a half-standing position. Arm rests optional.

X35

Construction as X 30, but the high chairs have a foot ring and floor glides to improve work safety.

X 40

A high quality Syncro tilt-mechanism allowing the angle of the seat and back to be adjusted separately with just one lever and your body weight. Tilt tension can be adjusted. A gas lift controls height adjustment. The back rest, tilt of seat and angle and height of back rest mechanically adjusted. With adjustable head rest. Swivelling twin castors, which are braked when unloaded, are standard. Upholstery 100 % wool. Arm rests optional.

X40L

As X40, but without head rest. Arm rests optional.

ARM

The arm rests have a 80mm height range, 60 mm width range and 50mm depth range. They can be set either forwards or backwards. By reversing the armrests you can sit closer to the workbench.

This chair range fulfils seating requirements from the production environment through to the office and meeting room. Optimum ergonomics improve workplace.

Code	Upholstery	Seat height mm	Seat size D x W mm	Back size D x W mm
X 30 B	blue	410...550	445 x 455	370 x 275
X 30 G	grey			
X 30 R	red			
X 32 B*	blue	450...650	445 x 455	370 x 275
X 32 G*	grey			
X 32 R*	red			
X 35 B	blue	500...740	445 x 455	370 x 275
X 35 G*	grey			
X 35 R*	red			
X 40 B	dark blue	420...560	475x 455	510 x 430
X 40 G	grey			
X 40 R	red			
X 40L B*	dark blue	420...560	475x 455	510 x 430
X 40L G*	grey			
X 40L R*	red			



*) To order

industrial chairs X

Design Yrjö Kukkapuro & Reijo Raatesalmi



These durable industrial chairs constructed with a cushioned polyurethane seat and back that can be washed or steam cleaned. The chairs are very comfortable to sit in and offer excellent lumbar support. The grooves act as lines giving the chairs a new strong visual effect and lightness.

X 20 PU

A gas lift controls height adjustment. Tilt of seat and angle and height of back rest mechanically adjusted. The black polyurethane seat and back. Swivelling twin castors, which are braked when unloaded, are standard. Arm rests optional.

X 25 PU

Construction as X 20 PU, but the high chairs have a foot ring and floor glides for additional stability. Arm rests optional.

X 10 PU

Stool. A black polyurethane seat Ø 350 mm. Swivelling twin castors, which are braked when unloaded, are standard.

AR

The arm rests have a 80mm height range 60 mm width range and 50mm depth range. They can be set either forwards or backwards by reversing the armrests you can sit closer to the workbench.

Code	Seat height mm	Seat size D x W mm	Back size D x W mm
X 20 PU	400...540	370 x 425	350 x 265
X 25 PU	490...730	370 x 425	350 x 265
X 10 PU	470...510	Ø 350	-



Foot rest JT 2

The feature of this foot rest is the fluted exercise roller which revitalises the feet while working. The surface is corrugated to prevent slipping. Colour grey. Material polystyrene. Dimensions: 500 x 370 x 100 mm.



Saddle stool KJ 200

Saddle seat. Tilt of seat adjustable. Seat height: 540... 800 mm. Foot rest to order.



industrial office screen system

The compact and modern Treston Industrial Office Screen system with panel and accessory options can be used almost anywhere; from production facilities to offices. Noise from production areas or loud talking from neighbouring workstations are often disturbing factors. One way of reducing the noise level is to divide workspaces from each other and/or separate them from production areas. This can be easily done with Treston screens. An individual workstation aids concentration and improves accuracy. With Treston screens noise levels can be reduced on average, by 7-9 dB to the standard ISO 10053. (VTT Research Centre Finland).

Divider screen panels can be used individually, in straight lines, or at right angles to form enclosed spaces. Create a uniform, stylish look with Treston screens throughout your company! Please ask for more details, we will help you out.

Acoustic panel

An anodized aluminium frame holds panels made of blue or grey fabric paneling. Acoustic panel: polyether/wood. Thickness: 32 mm .







Perforated screen panels

An anodized aluminium frame holds panels made of perforated panel. The perforated steel panel is epoxy powder coated in light grey RAL 7035, 9 mm perforations at 38 mm centres.

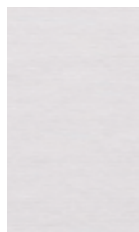
Legs

- TLEG 400 is suitable for all low panels, and high fabric panels.
Complete assembly's height:
1275 - 1315 mm (low panels)
2030 - 2070 mm (high panels)
- TLEG 600 is suitable for all high panels, fabric and steel.
Adjustable feet are provided for fine levelling. Complete assembly's height: 2070 - 2080 mm.
- CLEG- corner leg set for all panels. Can be used with two panels to create a 90 deg corner.
- LLEG 250 is suitable for all low panels, and high fabric panels.
Complete assembly's height:
1275 - 1315 mm (low panels)
2030 - 2070 mm (high panels)
- One screen panel will need a panel and two legs, which are ordered separately.
- Straight line assemblies require two legs for the first panel and one leg for each additional panel.



Screen panels				Suitability of legs (ordered separately, 1 pcs per pack)			
			Outer dims L x H mm				
Blue fabric	Grey fabrics	Perf. panel		T-leg 400	T-leg 600	L-leg 250	Corner leg set
P 0712 FB	P 0712 FG	P 0712 S	750 x 1245	TLEG400	—	LLEG250	CLEG
P 0720 FB	P 0720 FG	P 0720 S	750 x 2000	TLEG400*	TLEG600	LLEG250*	CLEG
P 1012 FB	P 1012 FG	P 1012 S	1050 x 1245	TLEG400	—	LLEG250	CLEG
P 1020 FB	P 1020 FG	P 1020 S	1050 x 2000	TLEG400*	TLEG600	LLEG250*	CLEG

*) We recommend this leg for the low panels but it can be mounted to high fabric panels and all corner layouts.



3

SCREEN COMBINATIONS

No. 1 Combination includes

- 2 pcs acoustic panel P 1012 FG, 1050 x 1245 mm
- 3 pcs leg TLEG 400
- 3 pcs bin rail PBP 100 ESD

No. 2 Combination includes

- 4 pcs acoustic panel P 1012 FB, 1050 x 1245 mm
- 4 pcs leg TLEG 400
- 1 pcs corner leg GLEG
- 2 pcs steel shelf PSS 100 ESD.

No. 3 Combination includes

- 4 pcs perforated steel panel P 0720 S, 750 x 2000 mm
- 5 pcs leg TLEG 600
- 1 pcs bin rail PBP 100 ESD.

No. 4 Combination includes

- 6 pcs acoustic panel P 1012 FB, 1050 x 1245 mm
- 6 pcs leg TLEG 400
- 1 pcs corner leg GLEG
- 2 pcs workbench WB 811, 800 x 1073 mm
- 1 pcs corner worktop WB 1212 CT, 1153 x 1153 mm
- 1 pcs aluminium profile AL2X 110
- 1 pcs adjustable shelf ASH 110, 400 x 960 mm
- 1 pcs support bracket HSB 110
- 1 pcs lighting unit OL 254
- 1 pcs cable channel CJK 100 SET
- 1 pcs chair X 40L R



4

ACCESSORIES

Bin rail PBP

Aluminium rail for TRESTON stacking bins 1015, 1520, 1525 and 1930. Load capacity 10 kg. Aluminium profile/semiconductive epoxy powder coated steel. Max 3 profiles/one side.

Steel shelf PSS

Steel semiconductive epoxy powder coated shelf. The shelf can sit on the brackets as normal or hang from the brackets to provide end stops. Load capacity 10 kg. Max 3 shelves/one side.

Power channel PJK

May be fitted with a choice of components, ordered separately. All meet with CE requirements. 3 m cable is included. Supplied wired and ready for use.

COMPONENTS: E1 double socket, E2 switch, E3 automatic fuse 10 A, E4 automatic fuse/earth leakage switch 10 A/30 mA, E5 emergency-stop-switch, E6 data connector/shielded for Cat.6 cable, E7 data connector for Cat.5, E8 pneumatic, quick coupling 3/8" Cat 5)



Bin profile	profile
PBP 70 ESD	700 mm
PBP 100 ESD	1000 mm

Steel shelf	D x L
PSS 70 ESD	170 x 710 mm
PSS 100 ESD	170 x 1010 mm

Cable channel	profile
PJK 70	640 mm
PJK 100	940 mm

packing station PPH



1. Packing bench PPH

Well-presented packages and parcels give an important first impression for any company. TRESTON packing stations ensure that valuable and vulnerable products are packed on equipment specifically designed for the task. Height adjustment of worktops 760...1050 mm. The worktop overhangs the frame by 300 mm and this can be set to the left or right side during assembly. Bench with upright profiles and a laminate shelf, height adjustment between 1100...1650 mm: the upper shelf has 6 steel divider hoops for holding cartons. Supports for paper and cardboard rolls. Frame construction of the packing bench is the same as TP/TPH-workbenches, so TPH accessories can be used.

Code	Worktop mm	Frame mm	Load capacity
PPH 918	900 x 1800	900 x 1500	300 kg
PPH 921	900 x 2100	900 x 1800	300 kg

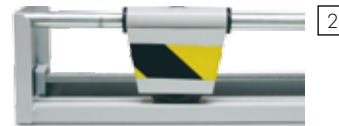

ACCESSORIES

2. Cutter PPL 170

Cuts paper, corrugated cardboard and most other packaging materials - not suitable for bubble wrap. Frame is of epoxy powder coated steel in light grey RAL 7035. Total length 1700 mm. Cutting length 1500 mm.

3. Equipment bin PPH-TL

For tape roll and scissors etc. A red stacking bin 1950-5 with an underbench supporting frame for packing equipment. Dimensions of bin 500 x 186 x 182 mm.

COMBINATIONS

No. 4 Combination includes

1 pcs packing bench PPH 918, worktop 900 x 1800 mm
1 pcs cutter PPL 170
1 pcs equipment bin PPH-TL

No. 5 Combination includes

1 pcs packing bench PPH 918, taso 900 x 1800 mm
1 pcs angle extension TP 510K, taso 500 x 1000 mm

No. 6 Combination includes

1 pcs packing bench PPH 918, taso 900 x 1800 mm
1 pcs cutter PPL 170
1 pcs equipment bin PPH-TL
1 pcs moveable bench SAP 507, taso 500 x 700 mm
1 pcs lower shelf AT 507



Treston reserves the right to amend specifications without prior notification.

TRESTON[®]
RELIABLE INDUSTRIAL FURNITURE

TRESTON OY
Sorakatu 1
FI-20730 Turku
FINLAND
Tel. +358-2-277 9000
Fax +358-2-236 1140
sales@treston.com
www.treston.com