



THE WORLD LEADER IN
FUME EXTRACTION TECHNOLOGY

PP 800 DS

PrintPRO

The PrintPRO 800 DS is BOFA's mid to high end range of fume extraction and filtration system. The PrintPRO 800 DS has been purposely designed to filter the fumes generated from Dye Sublimation printers. This extraction system combines extremely large filter capacity with high airflows and pressure. This combination makes it ideal for heavy duty applications that generate large amounts of gaseous organic compounds. This system benefits from Automatic Flow Control, which enables the end user to set the required airflow for the application. The unit will then maintain this airflow throughout the life cycle of the filters.

The additional feature of BOFA's 'Easi-Seal' filter location mechanism makes filter change easy, quick and safe. A truly state of the art fume purification solution.

STANDARD FEATURES:

- Hydrophobic HEPA Filters
- Turbines with high airflow and pressure
- Filters with long life and low replacement cost
- Automatic flow control system
- Automatic fluid drain
- Fluid collection tray

Mid to high end fume extraction system for Dye Sublimation printers.



Automatic Flow Control

OPTIONAL FEATURES:

- VOC gas sensor (Volatile Organic Compound)
- Remote stop / start interface
- Filter change / System fail signal



PART NUMBERS					
Model	Voltage	Part No.	24V Stop / Start	Filter change / System failure signal	VOC Monitoring
PrintPRO 800 DS Powder Coated Stainless Steel	115V - 230V	L3842A	A2001	A2002	A2003

REPLACEMENT FILTERS			
Model	Sponge Filter (x 2)	Gas Filter	HEPA Filter
PrintPRO 800 DS	A1030245	A1030246	A1030243

TECHNICAL DATA		
	CE	US
Dimensions (HxWxD)	1175 x 600 x 750mm	46.2 x 23.6 x 29.5"
Cabinet Construction	Powder coated stainless steel	Powder coated stainless steel
Airflow / Pressure	800m³/hr / 96mbar	470cfm / 96mbar
Electronical Data	90-257v 1ph 50/60Hz Full load current: 25 amps / 2.2kw	
Noise Level	< 68dBA*	< 68dBA*
Weight	155kg	342lbs

* At typical operating speed.

SPONGE COALECENT FILTER (X 2) SPECIFICATIONS	
Foam Media	58 Grade open cell foam
Dimensions (HxWxD)	600 x 500 x 150 (x2)

HEPA FILTER SPECIFICATIONS	
Surface Media Area	7.5m² approx
HEPA Filter Media	Hydrophobic Glass Fibre
HEPA Media Construction	Maxi Pleat Construction with Webbing Spacers
Filter Efficiency	H13 (99.997% @ 0.3 microns)
Filter Housing	Zintec Mild Steel

GAS FILTER SPECIFICATIONS	
Treated Activated Carbon	25kgs
Filter Housing	Zintec Mild Steel

Other hose kits and filters are available. All of the above units are fitted with our standard filter combinations. For specific applications please call us for details. Replacement filters should always be ordered using the part number on the filters inside your extractor to ensure the correct filter is ordered. Datasheet correct at time of print.

AIRFLOW THROUGH FILTERS

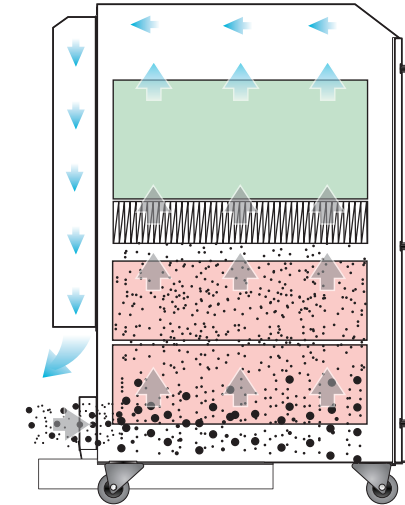
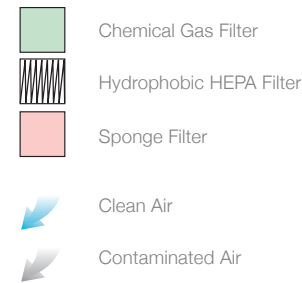

TECHNICAL SPECIFICATION

- 1 Unit / Filter Condition Display - Automatic Flow Control
- 2 On / Off Isolator Switch
- 3 Signal / Interface Cable
- 4 Power Cable
- 5 Castors
- 6 Door Hinge
- 7 Hose Inlet Connection - 125mm
- 8 Exhaust Outlet
- 9 Motor Cooling Inlet
- 10 Door Latch
- 11 Removable Fluid Collection Tray
- 12 Automatic Drain

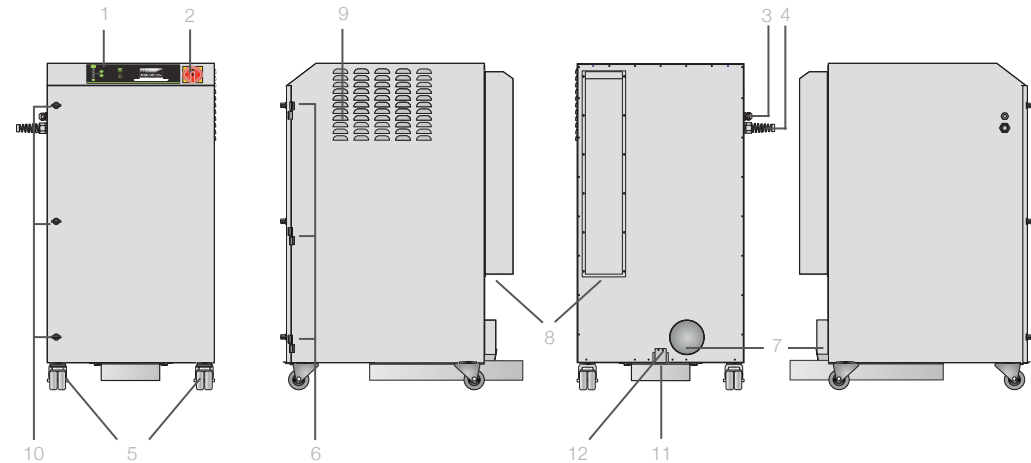

Date:16/2/12 V1.2



BOFA INTERNATIONAL LTD

Tel: +44 (0) 1202 699 444 Fax: +44 (0) 1202 699 446 Email: sales@bofa.co.uk Web: www.bofa.co.uk

BOFA AMERICAS, INC

Tel: (618) 635 4465 Fax: (866) 707 2632 Email: sales@bofaamericas.com Web: www.bofaamericas.com

