

STENCILPRINTER

TECHNO-SD/240

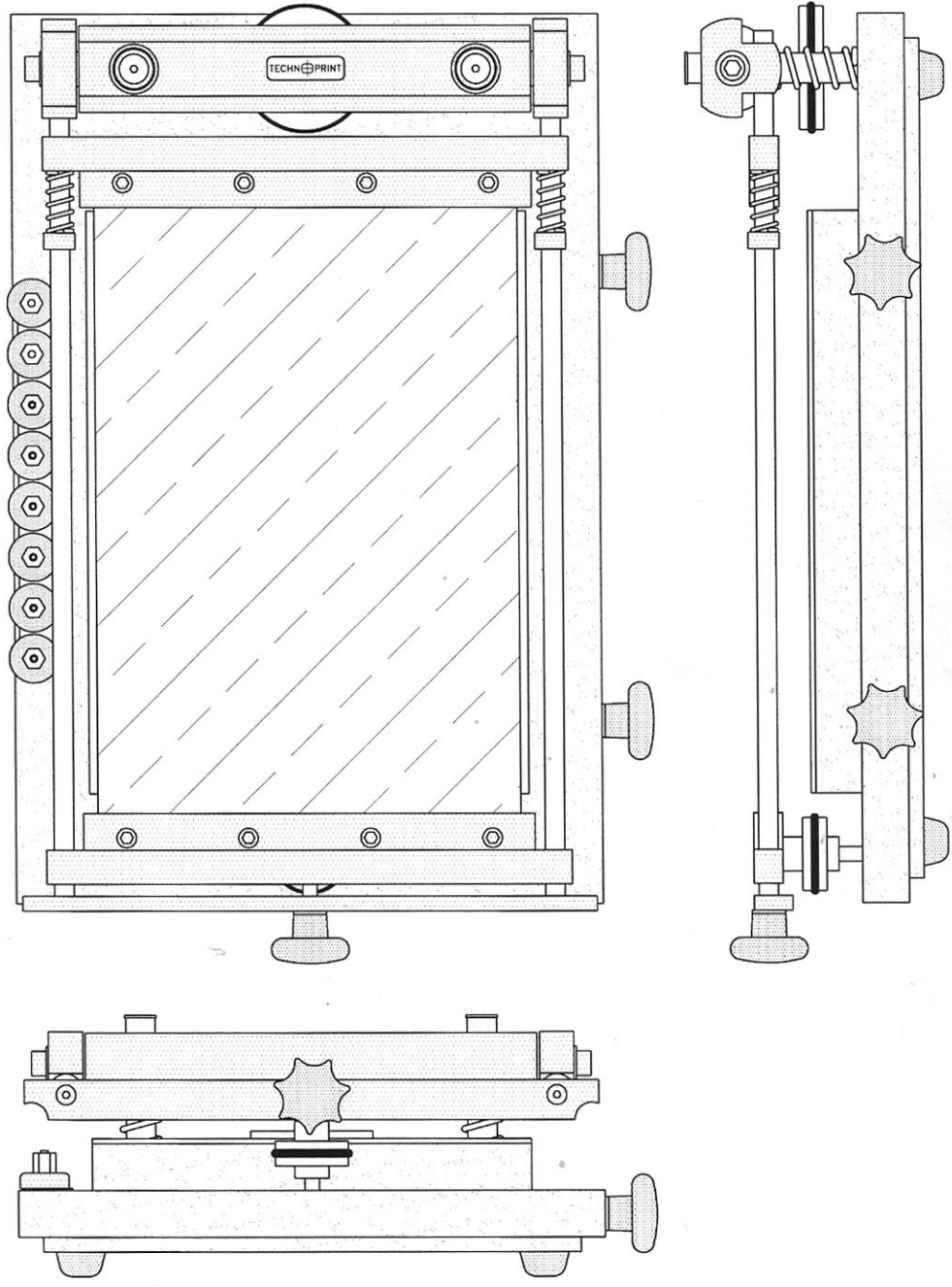

Table of contents

Introduction	3
Product specification	3
Setting up the stencil printer	3
Placement of the stencil printer	3
Machine overview	4
Alignment controls	5
Getting started	6
Installing the stencil.	6
Installing the first PCB.	7
Operating the stencil printer.	8
Maintenance and care.	9
Cleaning the stencilframe.	9
Warranty:	9

Introduction

The TECHNO-SD/240 stencil printer is designed to put soldering paste on PCB's with a "stencil".

A stencil is a thin metal plate which has holes on the same positions as where the pads on the PCB are located.

Unlike other brands of stencilprinters, the TECHNO-SD/240 has unique features for user friendly handling of stencils and PCB's.

Some features are:

- * Stencils do not need mounting holes.
- * Fixing a stencil is fast and easy, no heating of the stencil is required.
- * Positioning of PCB's is simple but effective.
- * You may use the stencil printer for single as well as double sided PCB's even if there are already components on one side.

Product specification

Dimensions	:	240 x 370 x 110 mm.
Max. PCB	:	180 x 240 mm.
Max. Stencil	:	190 x 270 mm.
Weight	:	7 KG.

Setting up the stencil printer

Before unpacking look for damage on the outside of the machine and immediatly report it to the transport company. If you do not make remarks of transport damage on the freight papers, you have no right of insurance claims.

Carefully unpack the stencil printer and save the original package in case you need to ship the unit. Please check to be sure the following items are packed with your stencil printer:

- * 1 Stencil printer TECHNO SD/240
- * 1 Set of Allen Keys (metric) nr. 2, 3 and 4
- * 1 Non permanent marker pen (fineliner)
- * 6 Magnetic placeholders for PCB's
- * 2 Magnetic points of support for PCB's
- * 1 Transparent outline-plate to define PCB position
- * 1 Squeegee

Placement of the stencil printer

Place the stencil printer on a stable surface. Leave about 10 cm on each side of the machine free for easy acces to the X-axis, Y-axis and hight adjustments.

Machine overview

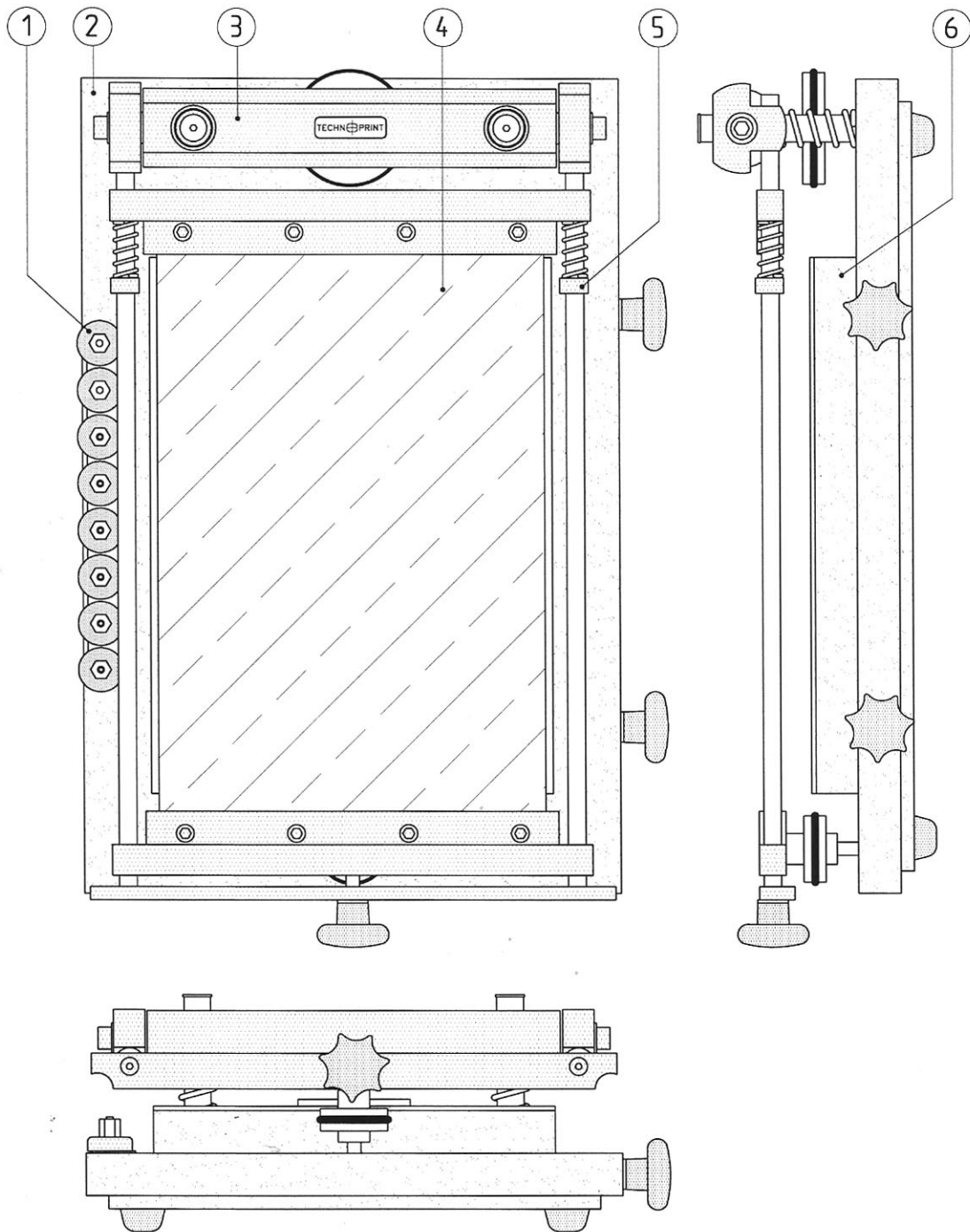

- 1 Magnetic placeholder storage
- 2 Base plate
- 3 Stencil frame
- 4 Stencil
- 5 Stencil size adjustment
- 6 PCB table

Alignment controls

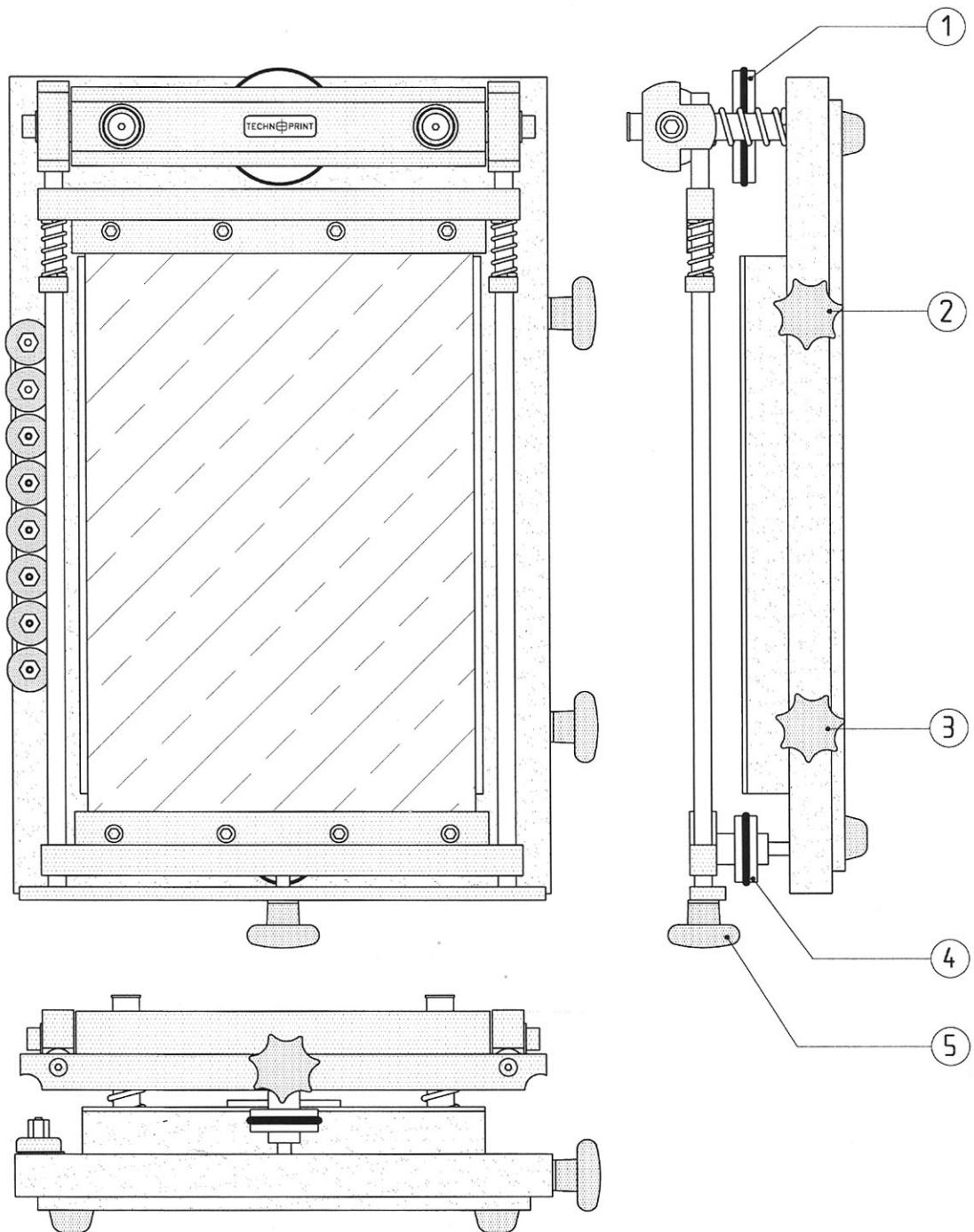

- 1 Top high adjustment of stencil
- 2 X-axis alignment and top rotation of PCB table
- 3 X-axis alignment and bottom rotation of PCB table
- 4 Bottom high adjustment of stencil
- 5 Y-axis alignment and stencil spanner

Getting started

Installing the stencil.

- 1 Loosen up the Y-axis alignment (stencil spanner) (A).
- 2 Unscrew the eight screws of the stencil frame (B)
- 3 Place the stencil in the first holder, make sure it is aligned.
- 4 Tighten the four screws.
- 5 Do the same for the second holder.
- 6 Tighten the Y-axis alignment to stretch the stencil.

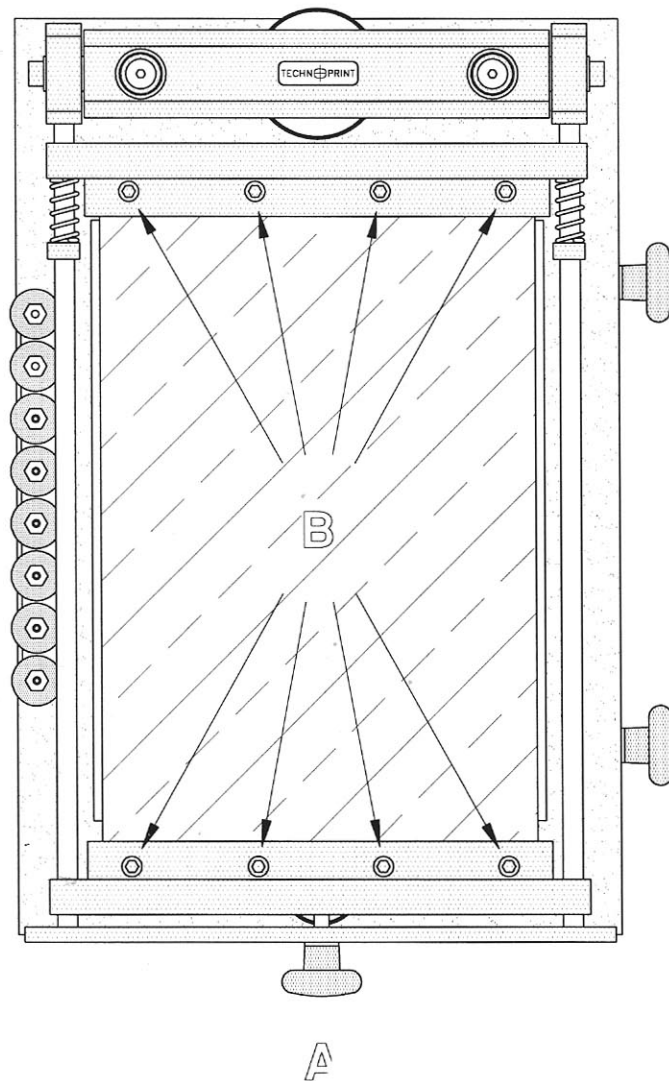

Installing the first PCB.

- 1 (See picture A) Open the printer.
- 2 Place the PCB roughly in its position with 4 or 6 magnetic place holders.
- 3 If needed, support the PCB in the middle with one or more magnetic points of support to prevent bending of the PCB.
- 4 Place the transparent outline plate over the PCB.
- 5 (See picture B) close the printer.
- 6 Use the marker pen and mark two easy to identify points on the PCB (the marks should naturally be made on the transparent outline plate)
- 7 Open the printer and adjust the two PCB soldering pads accordingly to the two marks on the outline plate.
- 8 Carefully remove the outline plate.
- 9 Close the printer and use the top and bottom height adjustments to make sure that the stencil position is just a fraction above the PCB.
- 10 Next use the X axis and Y axis controls for fine alignment of the stencil over the PCB.

You are now ready for printing.

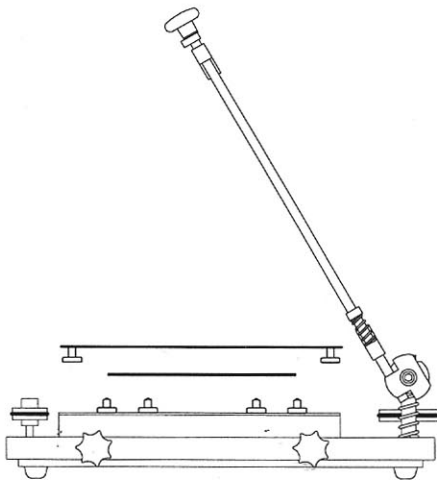

A

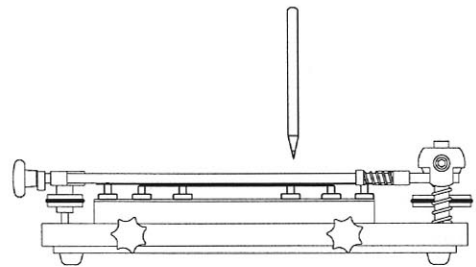

B

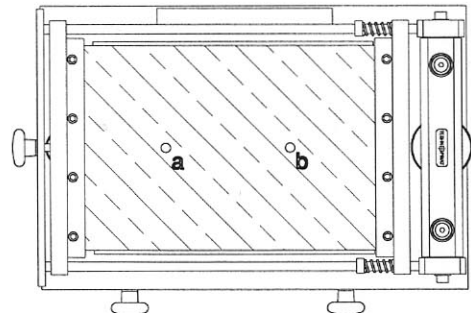
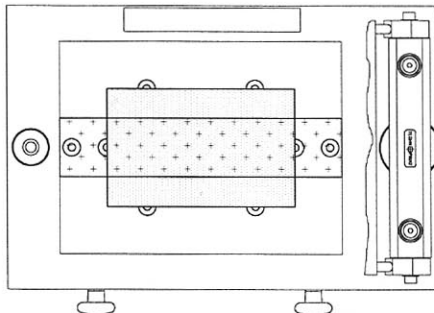

Operating the stencil printer.

Once installing is performed as described above, it is easy to place successive PCB's on the placeholders.

But be careful!

Due to the fact that PCB's can differ slightly among themselves, it is advisable to check if the PCB pads still exactly match the stencil holes before each printing.

- 1 Place a PCB on the place holders and close the printer as described before.
- 2 Put the solderpaste on the backside of the stencil with a spatula. Take care that the soldering paste is applied over the full width of the hole pattern.

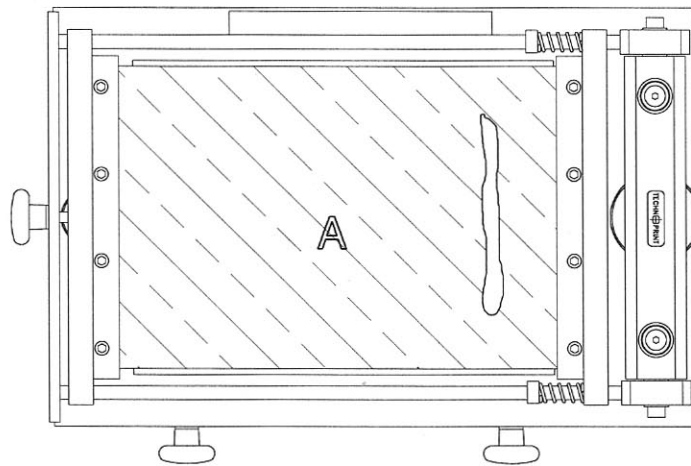

- 3 Place the squeegee behind the soldering paste and, in a blending way with a little pressure, move the squeegee to the frontside of the stencil. Take care that all the holes in the stencil are filled with soldering paste.

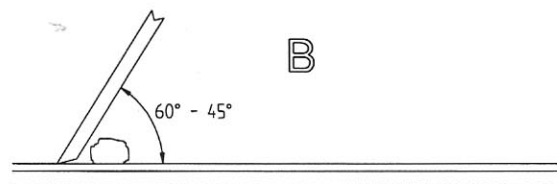

- 4 Remove the remaining soldering paste at the end of the stencil with the squeegee.
- 5 Carefully open the printer and remove the PCB.

Maintenance and care.

Use the Techno-SD/240 only in a dry, clean place and strictly avoid aggressive environmental conditions such as etching equipment.

Clean the soldering paste from the unit after use with a solvent that only removes soldering paste and has no aggressive elements in it that affect the machine or the stencil.

Note: to prevent corrosion, slightly oil all metal surfaces twice or several times per year with a resin and acid-free machine oil.
(no further lubrication is needed or advised).

Cleaning the stencilframe.

For easy cleaning of the stencilframe, turn the Top hight adjustment knob 'A' clockwise until you can lift the frame from the baseplate. After cleaning, replace the frame on the baseplate and turn the Top hight adjustment knob 'A' counter clockwise to secure it.

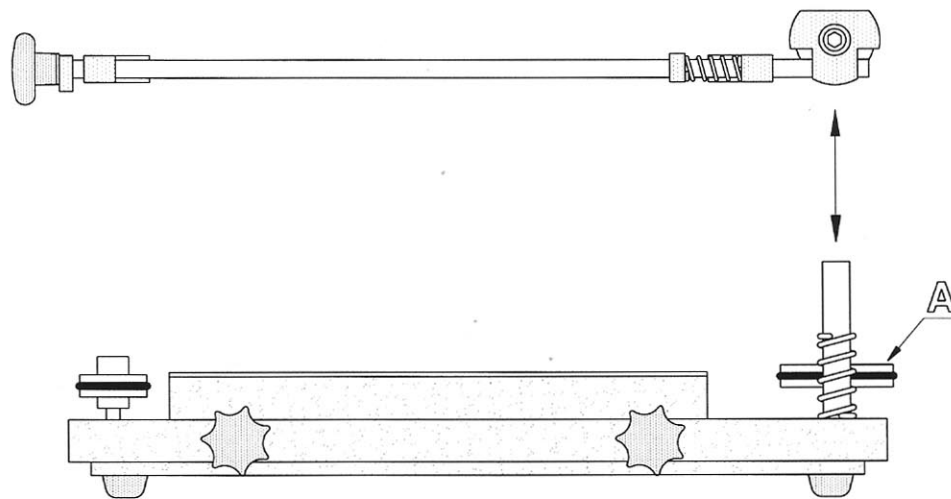

Warranty:

Like all of our other products the Techno-SD/240 has a full one year warranty against faults in material or production.

Any defective part under this warranty will be repaired or replaced at our cost. The part in question, or the whole unit, has to be returned to us (transportation payable by the customer) together with a detailed description of the fault.

Defects due to normal wear as well as defects due to wrong use or lack of care are not covered under this warranty.